



*RAM 3000 Deluxe*<sup>TM</sup>  
*(AT Memory Expansion Board)*

OWNER'S MANUAL AND REFERENCE GUIDE  
EV-159  
(VERSION 3.0)

*EVER for EXcellence*

---

MAN-00109-30

*RAM 3000 Deluxe*<sup>TM</sup>  
*(AT Memory Expansion Board)*

OWNER'S MANUAL AND REFERENCE GUIDE  
EV-159  
(VERSION 3.0)

EVEREX SYSTEMS, INC.  
48431 MILMONT DRIVE  
FREMONT, CA 94538

# Notice

---

Everex Systems, Inc. reserves the right to make improvements in the product described in this manual at any time and without notice.

© Copyright Everex Systems, Inc., 1990

All rights reserved. No portion of this document may be copied, photocopied, reproduced, translated, or reduced to any electronic medium or machine readable form without prior written consent from Everex Systems, Inc.

August 1990 Edition

MAN-00109-30

While we do our best to avoid such a situation, Everex Systems, Inc. will not be responsible for any loss of information resulting from the use of this product. In no event will Everex Systems, Inc. be liable (i) to you for any incidental, consequential, or indirect damages (including damages for loss of business profits, business interruption, loss of business information, and the like) arising out of the use or inability to use this product even if Everex Systems, Inc. or any authorized Everex Systems, Inc. representative has been advised of the possibility of such damages, or (ii) for any claim by any other party.

Everex is a trademark of Everex Systems, Inc. EVER for EXcellence is a registered trademark of Everex Systems, Inc. IBM AT is a registered trademark of International Business Machines Corporation. Novell and NetWare are registered trademarks of Novell, Inc.

# Table of Contents

---

## **Section 1: Getting Started 1-1**

1.1 Features	1-1
1.2 System Requirements	1-2
1.3 Checklist	1-2
1.4 Section Summaries	1-3
1.5 Manual Conventions	1-4
1.6 READ.ME File	1-5
1.7 Installation Summary	1-5

## **Section 2: Configuration 2-1**

2.1 Physical Layout	2-1
2.2 Default Settings	2-2
2.3 About Jumpers and DIP Switches	2-3
2.4 Configuring With Software	2-4
Configuring Two or More RAM 3000 Deluxe Boards	2-7
2.5 Configuring Without Software	2-8
2.6 Jumper and DIP Switch Settings	2-9
Jumper W1	2-10
Jumper W2	2-10
DIP Switch SW1	2-11
DIP Switch SW2	2-13
DIP Switch SW3	2-16
2.7 Setting the AT Motherboard	2-19

## **Section 3: Hardware Installation 3-1**

3.1 Installing the DRAM Chips	3-1
3.2 Installing the RAM 3000 Deluxe	3-4
3.3 Testing the RAM 3000 Deluxe	3-7
3.4 Running the SETUP Program	3-8

**Section 4: Software Installation** **4-1**

4.1 EMS Device Driver (EMM.SYS)	4-1
Installing the EMS Device Driver	4-2
EMS Device Driver Parameters	4-2
EMS Device Driver Examples	4-4
4.2 RAM Disk Device Driver (EDISK.SYS)	4-5
Installing the RAM Disk Driver	4-6
RAM Disk Parameters	4-6
RAM Disk Driver Examples	4-8
4.3 Print Spooler (ESPOOL.EXE)	4-8
Installing the Print Spooler	4-9
Print Spooler Parameters	4-9
Print Spooler Examples	4-11

**Section 5: Troubleshooting** **5-1**

5.1 Quick Checkout	5-1
5.2 How To Get Help	5-3
Contacting Everex Technical Support	5-3
Returning Merchandise For Repair	5-4

**Appendix A: Memory Basics** **A-1**

A.1 Introduction to Base, Extended, and Expanded (EMS) Memory	A-1
A.2 AT Memory Space	A-2

**Appendix B: Expanded Memory (EMS) Technical Reference** **B-1**

B.1 Expanded Memory (EMS) Definition	B-1
B.2 Theory of Paging	B-2
B.3 Mapping Registers	B-3
B.4 EMS I/O Port Address Selections	B-4

**Appendix C: Interrupt Vector 67 (Hex) C-1**

C.1 Conflict With Interrupt Vector 67 (Hex) C-1

**Appendix D: For Extended Memory Users D-1**

D.1 Extended Memory Operating Systems D-1

**Appendix E: Creating a CONFIG.SYS File E-1**

E.1 CONFIG.SYS File E-1

**Glossary**

**Warranty**

**License Agreement**

**Index**

# Getting Started

---

Congratulations on the purchase of your new RAM 3000 Deluxe AT-compatible memory board developed by Everex Systems, Inc. The RAM 3000 Deluxe provides you with a winning combination of increased memory and more flexibility for your IBM AT or compatible. Before you configure and install your RAM 3000 Deluxe, you need to make some preliminary inspections as described in this section. This section also introduces you to this manual and some of the RAM 3000 Deluxe's features.

## Section 1 Summary

- 1.1 Features
- 1.2 System Requirements
- 1.3 Checklist
- 1.4 Section Summaries
- 1.5 Manual Conventions
- 1.6 READ.ME File
- 1.7 Installation Summary

## 1.1 Features

The RAM 3000 Deluxe comes with all of the following features:

- Adds up to 3MB of Random Access Memory (RAM) for base and/or extended memory upgrading
- Adds up to 3MB of RAM for memory addressed under the Lotus/Intel/Microsoft Expanded Memory Specification (LIM 4.0)
- Allows simultaneous coexistence of base, extended, and expanded memory on the same board
- Allows access to 32MB of expanded memory (maximum specified in LIM 4.0)

- Allows “window” size of more than four pages (page size is 16K)
- Allows the “window” to use pages in the backfill memory area (the base memory area between 256K and 640K)
- Fully compatible with AT-compatible motherboards that use the 80286-compatible CS8220 chip set
- 16-bit EMS transfer mode available for faster EMS operation

## 1.2 System Requirements

The items listed below are required to support the RAM 3000 Deluxe:

- IBM PC, AT or compatible computer
- Single 16-bit slot on AT bus
- DOS 3.20 or higher

## 1.3 Checklist

In addition to this manual, your RAM 3000 Deluxe carton should contain the following:

- One RAM 3000 Deluxe AT memory expansion board in an anti-static bag
- One 5.25-inch utility software diskette
- 256K (150ns or faster) Dynamic Random Access Memory (DRAM) chips (optional)
- Owner Registration and Warranty Card

If any of these items is missing or damaged, please contact the dealer from where you purchased your RAM 3000 Deluxe.



Save the packaging materials, sales invoice, and receipt in order to maintain your warranty and to prevent damage in case you need to ship your RAM 3000 Deluxe.

Note

---

Circuit boards are sensitive to static electricity, which can damage their delicate electronics. To protect your board, ground yourself before handling it. This can be accomplished by either wearing an ESD (Electro Static Discharge) wrist strap or by touching a metal surface, such as the chassis cover of your computer.

---

Caution

## 1.4 Section Summaries

This user's manual contains step-by-step instructions for installing the RAM 3000 Deluxe in your IBM AT or compatible. Here is a summary of what each section contains:

*Section 1: Getting Started* lists features and provides section summaries to introduce you to the RAM 3000 Deluxe and this manual.

*Section 2: Configuration* illustrates the RAM 3000 Deluxe and explains how to configure its jumpers and DIP switches.

*Section 3: Hardware Installation* includes instructions on installing DRAM chips onto the RAM 3000 Deluxe board. There are also details for installing the RAM 3000 Deluxe into your IBM AT or compatible.

*Section 4: Software Installation* provides information on installing the EMM.SYS EMS device driver, which is required when you configure your RAM 3000 Deluxe for expanded memory (EMS). Instructions for installing the optional EDISK.SYS RAM disk device driver and ESPOOL.EXE print spooler are also included.

*Section 5: Troubleshooting* provides suggestions for problems you can easily solve or tells you how to get technical assistance.

*Appendix A: Memory Basics* introduces you to memory and how it is allocated.

*Appendix B: Expanded Memory (EMS) Technical Reference* explains how expanded memory works within your system.

*Appendix C: Interrupt Vector 67 (Hex)* discusses how to resolve conflicts with other cards that also use Interrupt Vector 67 (Hex).

*Appendix D: For Extended Memory Users* explains how to configure the RAM 3000 Deluxe for "extended memory only" operating systems.

*Appendix E: Creating a CONFIG.SYS File* includes instructions on how to use the DOS COPY CON command to create or modify the CONFIG.SYS file.

The *Glossary* contains definitions of acronyms, abbreviations, and terms used in the manual.

The *Index* helps you locate specific information quickly.

## 1.5 Manual Conventions

This manual uses certain typographical conventions to help you obtain information quickly. Commands that you type are printed in a different font to isolate them from other text, and keys that you press are enclosed in brackets:

TYPE THIS COMMAND [↵]

The symbol [↵] following a command indicates a carriage return or [Enter] key. Throughout this manual, when you see [↵], you should press the [Enter] key.

Text that appears on your screen is separated from other text and is represented throughout this manual in *italics*:

*Press any key to return to DOS*

*Italic* type is also used for section titles or titles of other manuals or documents. For example: Installing DRAM is explained in *Section 3.1, Installing the DRAM Chips*.

Names of computer files and directories appear in **UPPER CASE** bold type.

<b>Note</b>	<b>Notes contain important information that is set off from the text.</b>
<b>Caution</b>	<b>Caution messages appear before procedures which, if not observed, could result in damage to equipment.</b>

**Warning messages indicate that when a specific procedure or practice is not followed correctly, personal injury could occur.**

**Warning**

The instructions and examples in this manual assume that you have at least one floppy diskette drive, designated as the A drive, and one hard disk drive, designated as the C drive. If this does not correspond to your own system, change these references in accordance with your system's configuration.

## 1.6 READ.ME File

Before you begin installation, place the RAM 3000 Deluxe utility diskette in Drive A. At the A prompt, type:

```
TYPE READ.ME [↵]
```

If this file is on the installation diskette, it will contain information available after this manual was printed.

## 1.7 Installation Summary

Use Flowchart 1-1 as a general guide to install the RAM 3000 Deluxe. For more detailed instructions, refer to the corresponding sections.

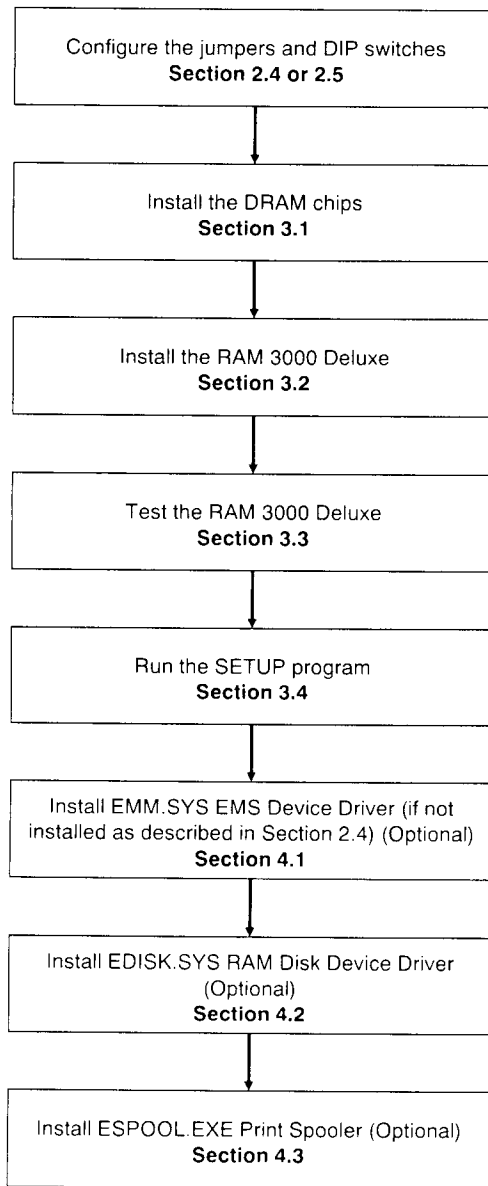

**Flowchart 1-1**      **Installation Summary**

# Configuration

---

Before you install the RAM 3000 Deluxe, you need to configure it by setting or confirming its jumpers and DIP switches. This section will guide you through the configuration of the RAM 3000 Deluxe.

## Section 2 Summary

- 2.1 Physical Layout
- 2.2 Default Settings
- 2.3 About Jumpers and DIP Switches
- 2.4 Configuring With Software
- 2.5 Configuring Without Software
- 2.6 Jumper and DIP Switch Settings
- 2.7 Setting the AT Motherboard

## 2.1 Physical Layout

The RAM 3000 Deluxe is a full length memory expansion board designed for the IBM AT or compatible computer. Figure 2-1 shows the RAM 3000 Deluxe layout.

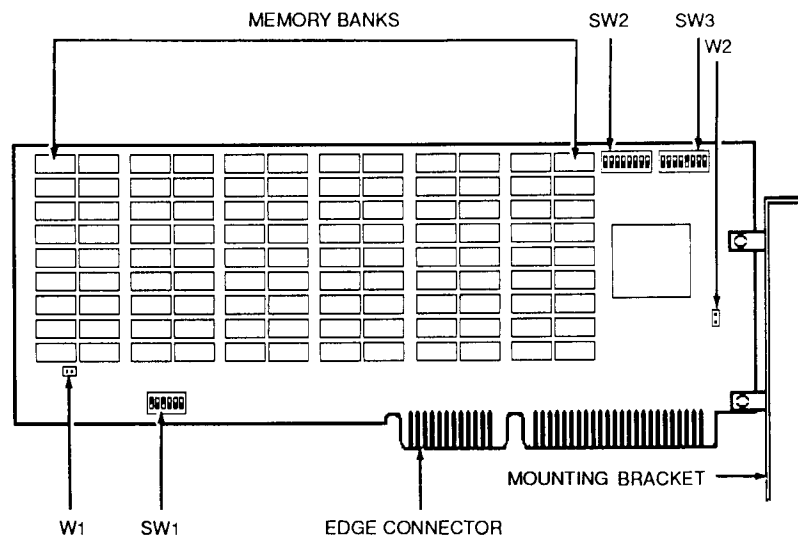

Figure 2-1 ► The RAM 3000 Deluxe

## 2.2 Default Settings

The RAM 3000 Deluxe leaves the factory with no memory chips installed, and with the jumpers and DIP switches configured as follows. To change these settings, refer to the corresponding jumper or DIP switch in *Section 2.6: Jumper and DIP Switch Settings*.

- The DRAM chips to be installed are rated at a speed of 120 nanoseconds or faster (Jumper W1)
- The memory parity checking mode is enabled (Jumper W2)
- The EMS I/O port address is set at Y258 Hex, where Y can be 0, 4, 8, or C (DIP Switch SW1)
- The EMS I/O port is disabled (DIP Switch SW1)
- It assumes one memory bank of RAM chips are installed (DIP Switch SW2)

- There is no contiguous memory space defined for base, extended, or expanded memory upgrading (DIP Switch SW2)
- The starting memory address is 1MB (100000H) (DIP Switch SW3)
- The EMS data transfer size is 8 bits wide (DIP Switch SW3)

If you are satisfied with these settings and do not want to modify the default configuration, proceed to *Section 3: Hardware Installation*.

## 2.3 About Jumpers and DIP Switches

To remove or adjust the placement of the jumper shunts, you can use a bent paper clip as shown in Figure 2-2. Insert the bent end into the hole at the top of the shunt and pull the jumper shunt up. (You can also use a paper clip to insert the jumper shunt onto the pins.)

**Do not change any jumper or DIP switch settings while the card is installed and the power is ON.**

**Note**

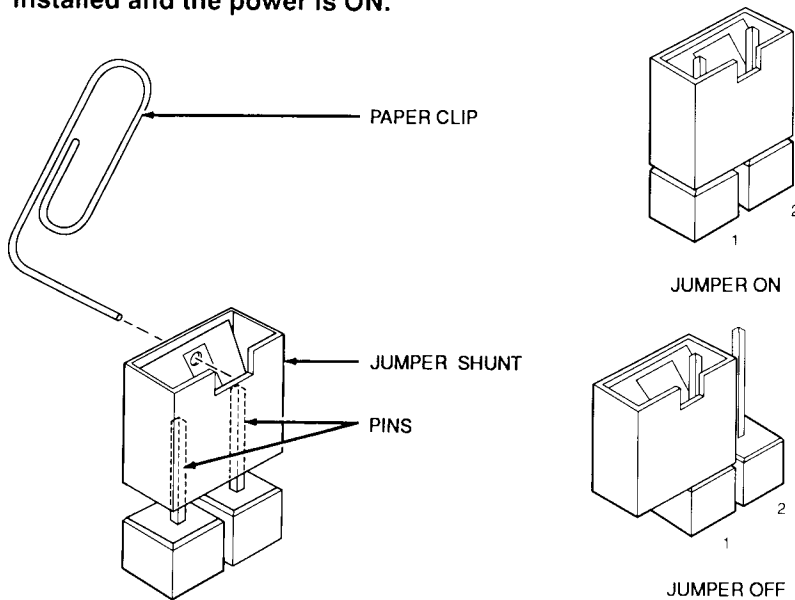

Removing Jumper Shunts

← Figure 2-2

Several different types of DIP switches may be installed on the RAM 3000 Deluxe. Figure 2-3 shows how to turn the DIP switch positions ON and OFF. Note that positions 1 to 4 are switched ON and positions 5 to 8 are switched OFF.

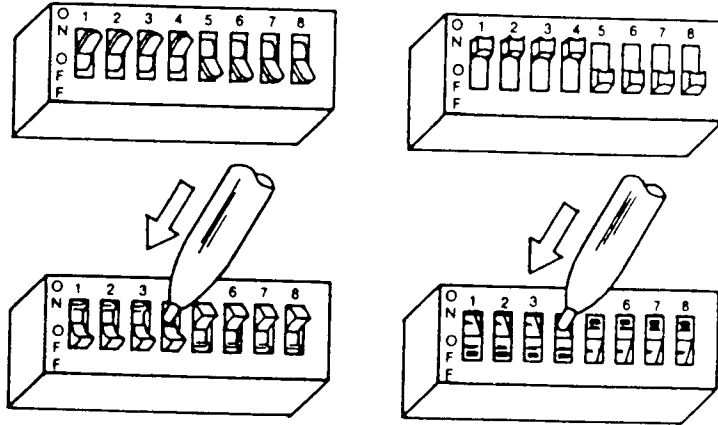

Figure 2-3 > The Different Types of DIP Switches

## 2.4 Configuring With Software

The RAM 3000 Deluxe utility diskette contains the `INST159.EXE` program used to configure your board. To run this program, insert the RAM 3000 Deluxe utility diskette in drive A and type:

```
A:
INST159
```

[↵]  
[↵]

The EV159 Utility Program Main Menu appears as shown in Figure 2-4.



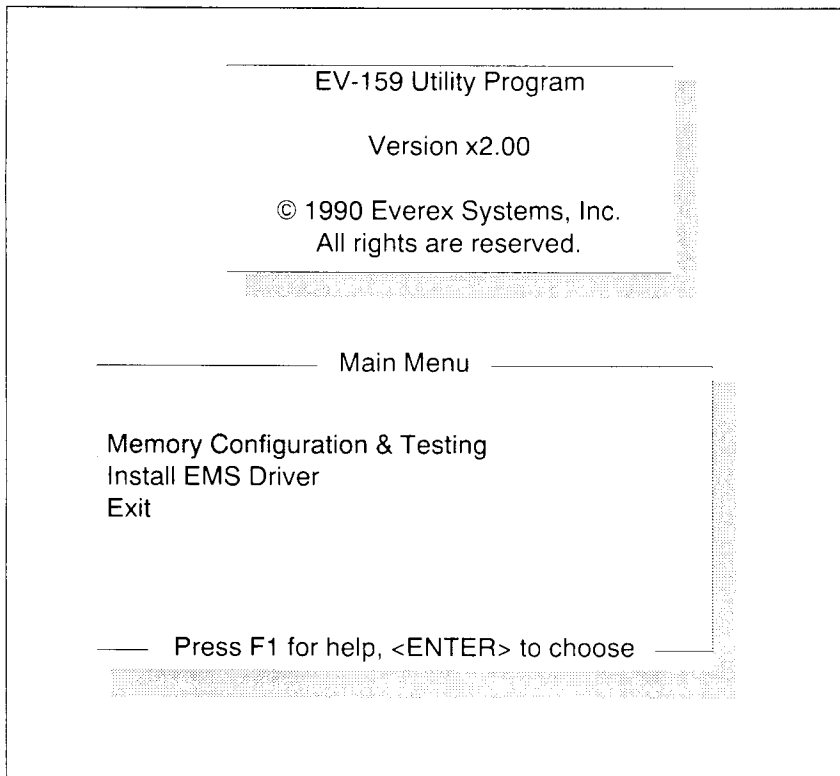

EV-159 Utility Program Main Menu

&lt; Figure 2-4

## Memory Configuration & Testing

1. From the Main Menu, select "Memory Configuration & Testing."

The "Testing" portion of this selection cannot be performed until the board is configured, the drivers installed, and the board is installed in your system. Complete all of these steps, and then proceed to *Section 3.3: Testing the RAM 3000 Deluxe*, to complete the "Testing" portion of this selection.

### Note

2. The Memory Configure screen appears as shown in Figure 2-5.

Configure Memory EV159 1.02 F1=Help F10=Exit

Amount of Existing Base Memory	(A Multiple of 128K)	640K
Amount of Existing Extended Memory	(A Multiple of 128K)	1024K
Amount of Base Memory to be Added	(A Multiple of 128K)	0K
Amount of Extended Memory to be Added	(A Multiple of 128K)	0K
Amount of EMS Memory to be Added	(A Multiple of 128K)	3072K
EMS I/O Port Address		258H

EMS Fast Mode	(Y/N)	N
The Speed of DRAMs is 120 Nanoseconds or Faster	(Y/N)	Y
Enable Parity Checking	(Y/N)	Y

↑ ↓ Move Cursor	F2 Config/Testing Menu	F4 Load Config	F8 Save Config
-----------------	------------------------	----------------	----------------

Figure 2-5 ► Memory Configuration Screen

- Use the cursor keys to move between the various menu fields. Enter your configuration option for each field. If you need help on any field, press the [F1] function key and a help screen will appear.
- After entering all your configuration options, press the [F2] function key; a screen representation of the card appears (this screen depicts the settings for the configuration options you selected in step 3). Manually set the jumpers and DIP switches according to the screen representation, and note the number of memory banks you must populate.
- Press the [F2] function key to return to the Memory Configuration screen.
- To save the current configuration, press the [F8] function key. When naming the configuration file, the **INST159.EXE** program suggests the configuration file name **EV159.001**. Press the [Enter] key to save this configuration file. You will need this saved file later when you test your RAM 3000 Deluxe as described in *Section 3.3: Testing the RAM 3000 Deluxe*.

7. Press the [F2] key, and then the [F10] key to return you to the Main Menu. Proceed to the next section to install the EMS Driver.

## Install EMS Driver

Install the EMS driver only if your board is configured with expanded memory.

Note

1. From the Main Menu, select "Install EMS Driver."
2. Enter the path of the subdirectory where you want the EMS Driver installed.
3. To back up your **CONFIG.SYS** file before it is modified, press [Y]. Your **CONFIG.SYS** will be modified to install the EMS driver. The old **CONFIG.SYS** is saved as **CONFIG.BAK**. If **CONFIG.BAK** already exists, you will be prompted to enter a new backup name.
4. Exit the **INST159.EXE** program and proceed to *Section 3: Hardware Installation* to install your RAM 3000 Deluxe board.

Refer to *Section 4.1: EMS Device Driver (EMM.SYS)* for information on customizing the EMS Device Driver.

Note

## Configuring Two or More RAM 3000 Deluxe Boards

If you install more than one RAM 3000 Deluxe board and are using the **INST159.EXE** program to configure each board, please note the following:

1. You must run the **INST159.EXE** program separately for each individual RAM 3000 Deluxe board installed in your system. When you finish the configuration for each RAM 3000 Deluxe board, you must save a unique configuration file for each board in your system (e.g. **EV159.001** for the first board, **EV159.002** for the second board, **EV159.003** for the third board, etc.).
2. If your system needs base memory upgrading, make sure to set only one of your RAM 3000 Deluxe boards for this function.

3. If your memory boards are configured for EMS memory, make sure that each board is set to the same data transfer mode (all set to 8-bit mode, or all set to 16-bit mode).

## 2.5 Configuring Without Software

To configure your RAM 3000 Deluxe board without using the included software, determine and configure the settings for each jumper and DIP switch. Table 2-1 lists the functions of each jumper and DIP switch. Proceed to *Section 2.6: Jumper and DIP Switch Settings* and configure each jumper and DIP switch.

Table 2-1 ➤ Jumper and DIP Switch Functions

JUMPER/DIP SWITCH	FUNCTION
W1	<ul style="list-style-type: none"> <li>• Selects the DRAM chip speed</li> </ul>
W2	<ul style="list-style-type: none"> <li>• Enables or disables parity checking</li> </ul>
SW1	<ul style="list-style-type: none"> <li>• Selects the EMS I/O port address</li> <li>• Enables or disables EMS I/O port</li> </ul>
SW2	<ul style="list-style-type: none"> <li>• Selects the number of memory banks filled</li> <li>• Defines contiguous memory space</li> </ul>
SW3	<ul style="list-style-type: none"> <li>• Selects between 8-bit or 16-bit EMS transfer mode</li> <li>• Selects starting address</li> </ul>

## 2.6 Jumper and DIP Switch Settings

Figure 2-5 shows the location of each jumper and DIP switch on the RAM 3000 Deluxe.

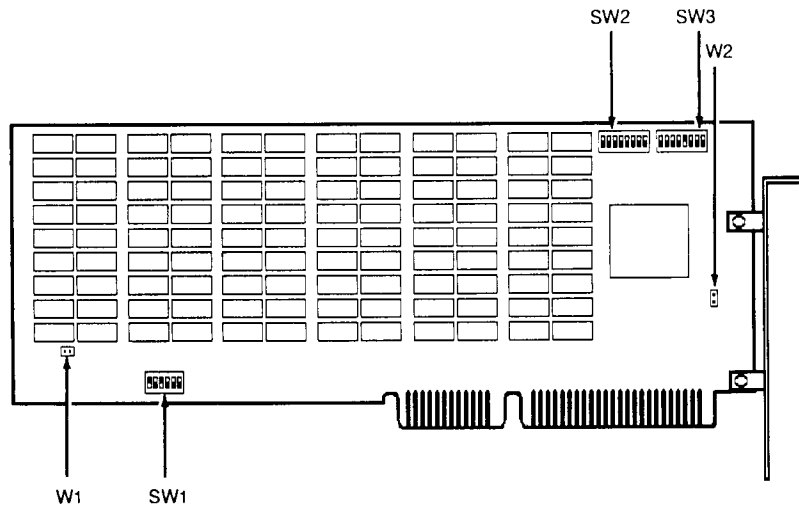

### Jumper and DIP Switch Locations

◀ Figure 2-5

If you are configuring your RAM 3000 Deluxe using the **INST159.EXE** program, set each jumper and DIP switch according to the screen representation of the board as explained in *Section 2.4: Configuring With Software*.

If you are configuring your RAM 3000 Deluxe without software, determine the setting and configure each jumper and DIP switch as instructed below.

**When configuring without software, and if any EMS memory space is defined, the EMS driver must be loaded and your CONFIG.SYS file must be modified. Refer to *Section 4.1: EMS Device Driver (EMM.SYS)* for instructions on how to do so.**

**Note**



## Jumper W1

Jumper W1 selects the speed of the 256K DRAM chips installed on the RAM 3000 Deluxe.

### Select the DRAM Chip Speed

All DRAM chips installed on the RAM 3000 Deluxe must be rated at the same speed. The default setting is for 256K DRAM chips with a speed of 120 nanoseconds or faster (the lower the number the faster the speed). If you want to install 256K DRAM chips with a speed of 150 nanoseconds, install a jumper shunt on jumper W1. Table 2-2 shows the settings for selecting DRAM chip speed.

Table 2-2 > Selecting DRAM Chip Speed

DRAM CHIP SPEED	W1 SETTING
120 nanoseconds or faster (default)	
150 nanoseconds	

#### Note

If your machine has a clock speed of 10MHz or faster, you must install 120 nanosecond or faster DRAM chips.

## Jumper W2



Jumper W2 allows you to enable or disable parity checking.

### Enable or Disable Parity Checking

The default setting is parity checking enabled. Because of the large amount of DRAM chips on the RAM 3000 Deluxe and the need for parity checking to insure the integrity of the data, jumper W2 should be left enabled. If you want to disable parity checking, remove the jumper shunt from jumper W2. Table 2-3 shows the setting for enabling and disabling parity checking.

## Enabling/Disabling Parity Checking

◀ Table 2-3

PARITY MODE	W2 SETTING
Enabled (default)	
Disabled	

## DIP Switch SW1

This 6-position DIP switch selects the EMS I/O port address and also enables or disables EMS mode. Table 2-4 describes the functions of DIP switch SW1 according to its positions.

In order to accommodate expanded memory (EMS) on your RAM 3000 Deluxe, an EMS I/O port address must be selected and also enabled.

Note

## DIP Switch SW1 Functions

◀ Table 2-4

POSITION	FUNCTION
1-4	Selects the EMS I/O port address
5	Enables or Disables EMS I/O port
6	Reserved

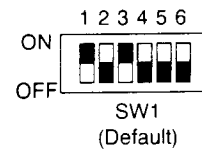

## Select EMS I/O Port Address (Positions 1-4)

Positions 1-4 select the EMS I/O port address. The default setting is for EMS I/O port address Y258. "Y" cannot be selected by the user; it has values of 0, 4, 8, or C. The RAM 3000 Deluxe uses only one I/O port for EMS data transfer.

To determine the memory address where the EMS I/O port will reside, set DIP switch positions 1-4 to inform the computer where to look for the EMS I/O port. Table 2-5 shows the possible settings for EMS I/O port addresses.

**Table 2-5** > **Selecting EMS I/O Port Address**

I/O PORT ADDRESS	POSITION			
	1	2	3	4
Y208	ON	ON	ON	ON
Y218	ON	ON	ON	OFF
Y258 (default)	ON	OFF	ON	OFF
Y268	ON	OFF	OFF	ON
Y2A8	OFF	ON	OFF	ON
Y2B8	OFF	ON	OFF	OFF
Y2E8	OFF	OFF	OFF	ON

**Note**

**Each expanded memory board installed in your system requires its own EMS I/O port address. If there is a conflict, select a different EMS I/O port address.**

**Enabling or Disabling EMS I/O Port (Position 5)**

Position 5 enables or disables the EMS I/O port. The default setting is enabled with position 5 OFF. In order to take advantage of EMS memory, position 5 must be enabled. Table 2-6 shows the setting for enabling or disabling the EMS I/O Port.



## Enabling or Disabling EMS I/O Port

◀ Table 2-6

EMS I/O PORT	POSITION
Enabled (default)	OFF
Disabled	ON

## DIP Switch SW2

This 8-position DIP switch selects the number of memory banks filled and the amount of contiguous memory defined on the RAM 3000 Deluxe. Table 2-7 describes the functions of DIP switch SW2 according to its positions.

## SW2 Functions

◀ Table 2-7

POSITION	FUNCTION
1-3	Selects number of 512KB memory banks filled
4-5	Selects active memory space in 1 MB increments
6-8	Selects contiguous memory space in 128KB increments

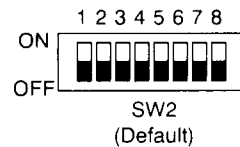

## Select Number of Memory Banks Filled (Positions 1-3)

Positions 1-3 set the number of banks populated with DRAM chips on the RAM 3000 Deluxe. Although there are no memory chips installed when the board leaves the factory, the default setting is for one bank of memory chips installed. Use Table 2-8 to configure positions 1-3 to correspond with the number of memory banks filled on the RAM 3000 Deluxe. Refer to *Section 3.1: Installing DRAM Chips*, for instructions on populating your board with DRAM chips.

Table 2-8 ➤ Number of Banks Filled

BANKS FILLED	POSITION		
	1	2	3
1 Bank (default)	OFF	OFF	OFF
2 Banks	OFF	OFF	ON
3 Banks	OFF	ON	OFF
4 Banks	OFF	ON	ON
5 Banks	ON	OFF	OFF
6 Banks	ON	OFF	ON

**Note** Avoid setting SW2 positions 1-3 to any other positions than those listed in Table 2-8.

### Define Active Memory Space (Positions 4-8)

DIP switch SW2 positions 4-8 define the amount of contiguous memory space used on the RAM 3000 Deluxe for base and/or extended memory upgrading. The amount that is selected must be a multiple of 128KB.

**Note** Any amount of memory that is not selected for base and/or extended memory upgrading is automatically available for expanded memory (EMS). If the RAM 3000 Deluxe is used for EMS memory only, do not define any contiguous memory space.

Positions 4-5 select contiguous memory space in 1MB (1024KB) increments while positions 6-8 select contiguous memory space in 128KB increments. The actual contiguous memory space defined for the RAM 3000 Deluxe is the sum of the amount represented by positions 4-5 and the amount represented by positions 6-8. By using both positions 4-5 and positions 6-8, any multiple of 128KB up to 3MB (3072KB) can be configured.

Table 2-9 lists the settings to define active memory space in 1MB (1024KB) increments. Table 2-10 lists the settings to define active memory space in 128KB increments.

Active Memory in 1MB (1024KB) Increments

◀ Table 2-9

MEMORY REPRESENTED (1MB INCREMENTS)	POSITION	
	4	5
0MB (default)	OFF	OFF
1MB	OFF	ON
2MB	ON	OFF
3MB	ON	ON

Active Memory in 128KB Increments

◀ Table 2-10

MEMORY REPRESENTED (128KB INCREMENTS)	POSITION		
	6	7	8
0KB (default)	OFF	OFF	OFF
128KB	OFF	OFF	ON
256KB	OFF	ON	OFF
384KB	OFF	ON	ON
512KB	ON	OFF	OFF
640KB	ON	OFF	ON
768KB	ON	ON	OFF
896KB	ON	ON	ON

## DIP Switch SW3

This 8-position DIP switch selects between 8-bit or 16-bit EMS transfer mode and also the memory starting address of the RAM 3000 Deluxe. Table 2-11 describes the functions of DIP Switch SW3 according to its positions.

Table 2-11 >

### SW3 Functions

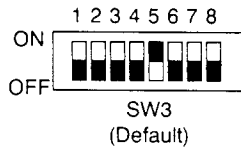

POSITION	FUNCTION
1	Selects between 8-bit and 16-bit EMS transfer mode.
2-5	Selects RAM 3000 starting address in 1MB increments.
6-8	Selects RAM 3000 starting address in 128K increments.

### Select Between 8-bit or 16-bit EMS Transfer Mode (Position 1)

Position 1 selects between 8-bit or 16-bit EMS transfer mode. Normally, the data transfer to and from expanded memory space is done with 8-bit wide data paths. For faster data transfer to and from EMS memory, set EMS transfer mode to 16-bits. Table 2-12 shows the setting for selecting between 8-bit and 16-bit EMS transfer mode. The default setting is for EMS transfer mode of 8-bits with position 1 set to OFF.

#### Note

The use of 16-bit EMS transfer mode may not work on AT compatibles with high bus speeds (8MHz or higher); we suggest experimenting with the RAM 3000 Deluxe to see if it will work. If your computer is a high-speed AT compatible and you cannot access expanded memory using the 16-bit EMS transfer mode, use the 8-bit EMS transfer mode so expanded memory can work properly.

### Selecting EMS Transfer Mode

◀ Table 2-12

EMS TRANSFER MODE	POSITION
	1
8-bit (default)	OFF
16-bit	ON

### Select Memory Starting Address (Positions 2-8)

DIP switch SW3 positions 2-8 define the memory starting address on the RAM 3000 Deluxe. The memory starting address that is selected must be a multiple of 128KB. Positions 2-5 select addresses in 1MB (1024KB) increments while positions 6-8 select addresses in 128KB increments. The actual memory starting address defined for the RAM 3000 Deluxe is the sum of the amount represented by positions 2-5 and the amount represented by positions 6-8. By using both positions 2-5 and positions 6-8, any multiple of 128KB, up to 15232KB, can be selected as the memory starting address. Table 2-13 lists the settings to define the memory starting address in 1MB (1024KB) increments. Table 2-14 lists the settings to define the memory starting address in 128KB increments.

The starting address of the RAM 3000 Deluxe can begin at 0KB-512KB (00000H-80000H) in base memory range or 1024KB-15232KB (100000H-EE0000H) in extended memory range by setting DIP switch SW3 positions 2-8. This means you can set the RAM 3000 Deluxe to accommodate both base and extended memory, even if the computer motherboard has 0 bytes of base memory installed. In addition, you can set up the RAM 3000 Deluxe so it works with AT-compatible motherboards using the CS8220 CHIPSet [upgrade base memory from 512KB to 640KB (80000H-9FFFFH) and upgrade extended memory beginning at 1536KB (180000H)].

**Note**

Table 2-13 ► Memory Starting Address in 1MB (1024KB) Increments

RAM 3000 STARTING ADDRESS (1MB INCREMENTS)	POSITION			
	2	3	4	5
0MB (000000H)	OFF	OFF	OFF	OFF
1MB (100000H) (default)	OFF	OFF	OFF	ON
2MB (200000H)	OFF	OFF	ON	OFF
3MB (300000H)	OFF	OFF	ON	ON
4MB (400000H)	OFF	ON	OFF	OFF
5MB (500000H)	OFF	ON	OFF	ON
6MB (600000H)	OFF	ON	ON	OFF
7MB (700000H)	OFF	ON	ON	ON
8MB (800000H)	ON	OFF	OFF	OFF
9MB (900000H)	ON	OFF	OFF	ON
10MB (A00000H)	ON	OFF	ON	OFF
11MB (B00000H)	ON	OFF	ON	ON
12MB (C00000H)	ON	ON	OFF	OFF
13MB (D00000H)	ON	ON	OFF	ON
14MB (E00000H)	ON	ON	ON	OFF
15MB (F00000H)	ON	ON	ON	ON

Memory Starting Address in 128KB Increments

&lt; Table 2-14

RAM 3000 STARTING ADDRESS (128K INCREMENTS)	POSITION		
	6	7	8
0K (00000H) (default)	OFF	OFF	OFF
128K (20000H)	OFF	OFF	ON
256K (40000H)	OFF	ON	OFF
384K (60000H)	OFF	ON	ON
512K (80000H)	ON	OFF	OFF
640K (A0000H)	ON	OFF	ON
768K (C0000H)	ON	ON	OFF
896K (E0000H)	ON	ON	ON

## 2.7 Setting the AT Motherboard

Your computer's motherboard has a switch/jumper which determines the maximum amount of active memory on the motherboard (in the IBM PC AT the jumper is marked J18). If your computer is an AT compatible, please check your computer's manual to see if any such switch/jumper exists. Refer to your owner's manual for instructions on how to set the switch/jumper to correspond with the active amount of memory on the motherboard.

The motherboard is on the bottom of the computer and contains the central processing unit of the computer. To set the switch, remove the cover of your computer. See *Section 3.2: Installing the RAM 3000 Deluxe Board* for details on how to remove the computer cover.

If you have an IBM PC AT and 256KB of active RAM, set J18 to the 256K position. If your IBM PC AT has 512KB of active RAM, set J18 to the 512KB position. If the RAM 3000 Deluxe is the only memory expansion card in your computer, remember to set DIP switch SW3 on the RAM 3000 Deluxe card to correspond with the amount of memory on your motherboard. Refer to Figure 2-6 for the position of the J18 jumper block.

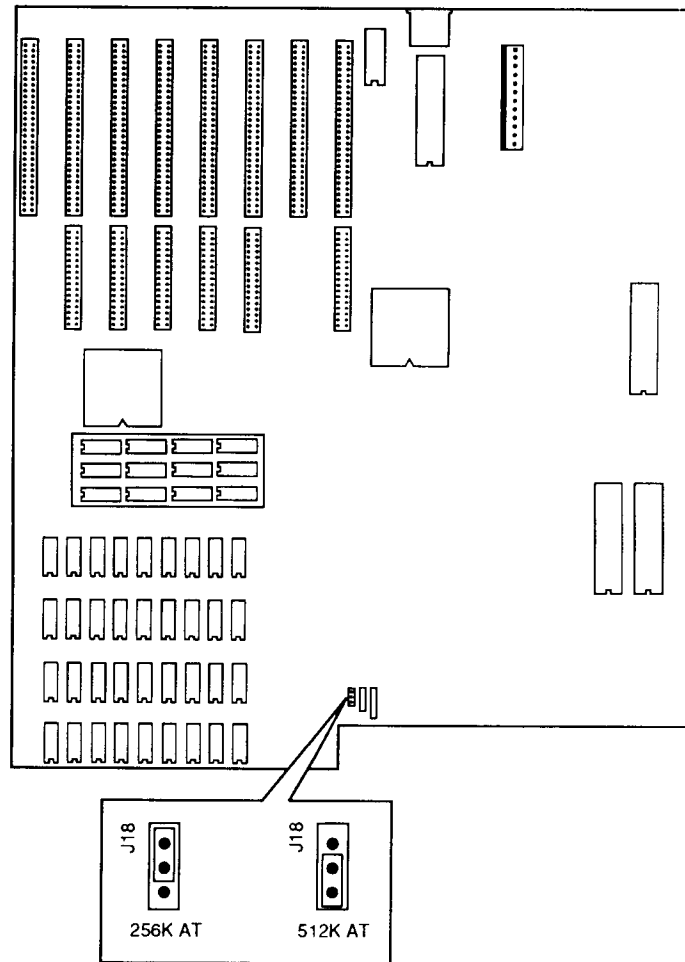

Figure 2-6 ➤ The IBM PC AT Motherboard



# Hardware Installation

---

This section includes instructions on installing DRAM chips onto the RAM 3000 Deluxe. There are also details on installing your RAM 3000 Deluxe into your IBM AT or compatible.

## Section 3 Summary

- 3.1 Installing the DRAM Chips
- 3.2 Installing the RAM 3000 Deluxe
- 3.3 Testing the RAM 3000 Deluxe
- 3.4 Running the SETUP Program

## 3.1 Installing the DRAM Chips

The process of adding DRAM (Direct Random Access Memory) memory chips to the RAM 3000 Deluxe is called populating. Your dealer may have already populated your memory board, or you can do it yourself. (If the RAM 3000 Deluxe is already populated with DRAM chips, proceed to *Section 3.2: Installing the RAM 3000 Deluxe.*)

---

**DRAM chips are extremely sensitive to static electricity. Even a mild shock can destroy a chip. To protect the chips, ground yourself before handling them. This can be accomplished by either wearing an ESD (Electro Static Discharge) wrist strap or by touching a metal surface, such as the chassis cover of your system.**

---

Caution

The RAM 3000 Deluxe uses only 256K-bit DRAM chips with a speed of 150 nanoseconds or faster. All DRAM chips installed must be rated at the same speed. Make sure Jumper W1 is set according to the speed of the DRAM chips installed as explained in *Section 2.5: Configuring Without Software.*

**Note**

If your computer has a 10MHz or faster clock speed, you must install 120 nanosecond or faster DRAM chips.

The RAM 3000 Deluxe has six banks (or vertical columns) of 18 chip sockets labeled Bank 0 to Bank 5 as shown in Figure 3-1.

Each of these banks must be either full or empty. You cannot leave any banks partially filled. For this reason, you must buy your DRAM chips in multiples of 18.

It is not necessary to fill all six banks on the RAM 3000 Deluxe; you can fill some of the banks now and fill the others at a later date. The only consequence is less memory for your use. (Make sure DIP switch SW2 is configured for the number of memory banks filled as explained in *Section 2.5: Configuring Without Software.*)

For every bank that is completely populated, 512KB of memory is added. The RAM 3000 Deluxe has a total capacity of 3MB (3072KB).

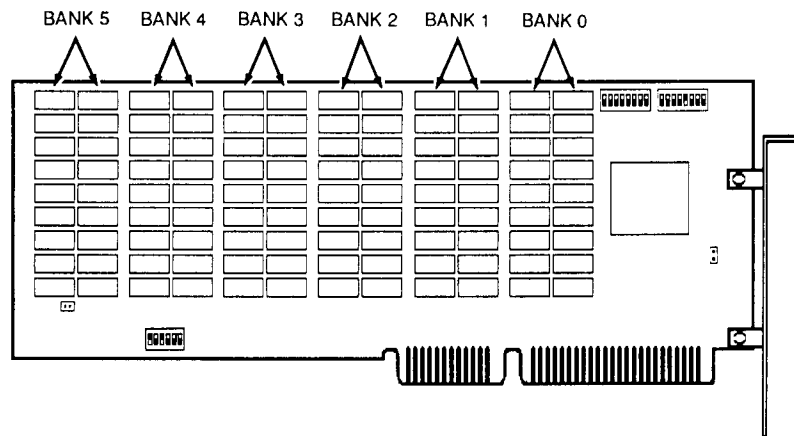

**Figure 3-1** ► Banks on the RAM 3000 Deluxe

Start by completely populating Bank 0 and move to the left for each subsequent bank. Do not skip any banks or leave any partially filled. Any empty banks should be to the left of a fully populated bank.

1. Each DRAM chip has a pin 1 which is marked with a notch or dot. If you look closely at each chip socket on your RAM 3000 Deluxe, you will see a notch at one end of the chip socket. Align the notch on the chip with the notch on the chip socket.
2. Each row of metal pins on the chip goes into a corresponding row of holes in the socket, as shown in Figure 3-2.

Insert the tips of the pins into their holes in the socket. Check that the alignment is exactly right, and press the chip into place. Only a small amount of pressure is needed to install DRAM chips; if you have to press hard, you are probably bending a pin. If you do bend a pin, carefully remove the chip, straighten the bent pin with a pair of pliers, and try again.

3. Repeat steps 1 and 2 to populate subsequent banks with DRAM chips.

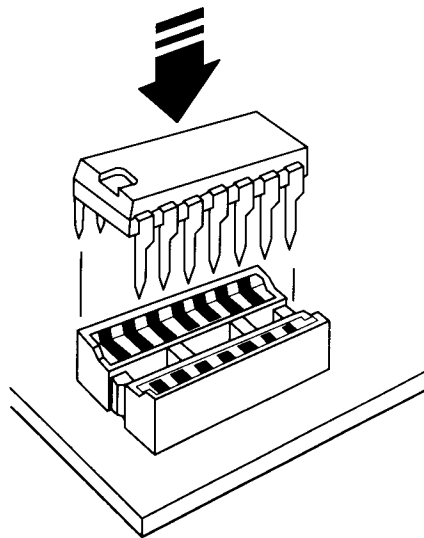

Installing a DRAM Chip

◀ Figure 3-2

## 3.2 Installing the RAM 3000 Deluxe

**Before you begin:** Remove your monitor(s) from the top of the computer and clear an area around your desk leaving plenty of room to work.

1. Turn OFF the power to your computer. Remove the power cord from both the computer and the AC wall outlet.

### Warning

**Before removing the cover or attempting any modifications, make sure that the power to the computer, as well as to all peripheral devices (such as printers), is OFF.**

2. Remove the retaining screws that hold the cover on your system. Slide the cover forward. When it stops sliding, tilt the cover up and lift it away as shown in Figure 3-3.

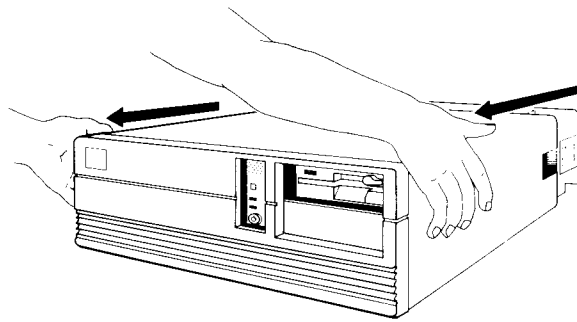
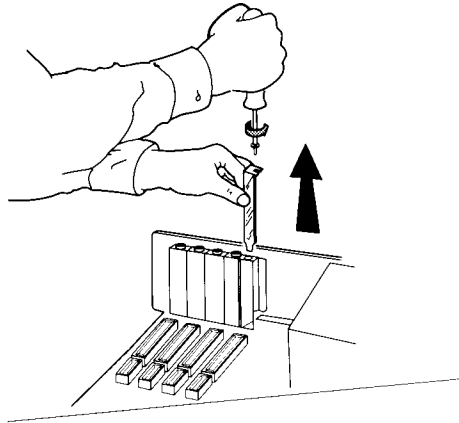

Figure 3-3 > Removing the Cover

3. Find an open 16-bit expansion slot (two-connector) and remove the retaining screw as shown in Figure 3-4. Save the slot cover so that you can replace it if you remove this card.



#### Removing the Expansion Slot Cover

◀ Figure 3-4

4. Hold the RAM 3000 Deluxe by its edges, gently slide the board into the expansion slot as shown in Figure 3-5.

Make sure that the board is seated securely in the slot and that the mounting bracket on the board aligns with the bracket slot on the back of the chassis.

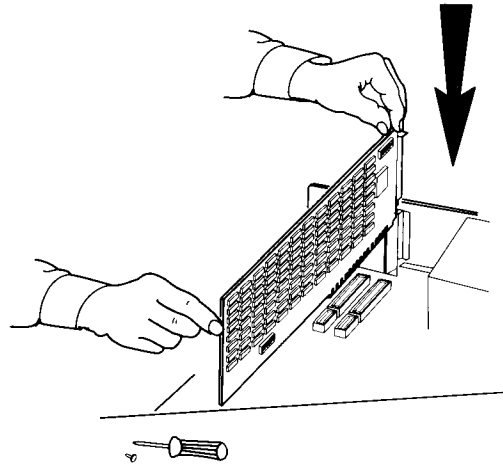

**Figure 3-5** ▶ **Installing the RAM 3000 Deluxe**

5. Using the retaining screw you removed earlier, secure the RAM 3000 Deluxe in the system.
6. Replace the computer's cover. Make sure to connect all the cables that were disconnected earlier.
7. The physical installation is complete. Now you are ready to test the RAM 3000 Deluxe to make sure all the DRAM chips are working properly as explained in *Section 3.3: Testing the RAM 3000 Deluxe*.

### 3.3 Testing the RAM 3000 Deluxe

The RAM 3000 Deluxe utility diskette contains the **INST159.EXE** utility program which contains the diagnostic program for the RAM 3000 Deluxe. This diagnostic program tests all the DRAM chips on the board to make sure that they are working properly. Use the following instructions to test the RAM 3000 Deluxe:

**If the EMS driver is already installed, it will be necessary to disable it in order to test the RAM 3000 Deluxe. This must be done before re-booting your system with DOS. One way to disable your driver is to rename it by changing a single character. For example, use the DOS RENAME command to rename "EMM.SYS" to "EMM.SYX". When the system re-boots, the EMS driver will not be recognized and the board test can continue. After the test is completed, make sure to rename the driver back to EMM.SYS.**

Note

1. Boot up your system with DOS.
2. Insert the RAM 3000 Deluxe utility diskette into drive A and type:

```
A:                                     [↵]
INST159                               [↵]
```

The EV159 Utility Program Main Menu appears.

---

**Do not run the INST159.EXE memory test if you have valuable data loaded in the RAM 3000 Deluxe, as this program will overwrite all data.**

---

Caution

3. From the Main Menu, select "Memory Configuration & Testing." The Configure Memory screen appears.
4. Load the Configuration File that was stored on disk in *Section 2.4: Configuring With Software* by pressing the [F4] key and entering the path and name of the configuration file.

5. Press the [F5] key to begin the test. The memory test locates any bad chips (bad chips are shown blinking). Make sure you have loaded the correct configuration file, and check the chips at the locations represented on the screen to ensure the chips are installed correctly (did you bend or break the chip pins or improperly orient the chip?) If the chips are installed properly, you must replace the bad chips.
6. Press the [F2] key to get to the Main Menu, and exit the program.

### 3.4 Running the SETUP Program

Once the RAM 3000 Deluxe board test is completed, run the SETUP program on the IBM AT Advanced Diagnostics diskette. This program informs your system of the new memory expansion board so application software can access the board.

1. Boot up your system with the IBM AT Advanced Diagnostics diskette in drive A.
2. Choose the SETUP option
3. Follow the instructions as they appear on the screen.

**Note**

**AT compatibles have various methods of running the SETUP program. Check your owner's manual for instructions on how to run the SETUP program for your particular computer.**



# Software Installation

---

The RAM 3000 Deluxe utility diskette contains three device drivers and a print spooler program to enhance the productivity of your card:

**EMM.SYS**  
(or **EMML.SYS**)      Software device drivers that make expanded memory space available to programs that can access it. The **EMML.SYS** device driver replaces the **EMM.SYS** device driver in special cases. The **EMM.SYS** driver should be installed first. If there is a need for **EMML.SYS** instead of **EMM.SYS**, the driver informs you.

**EDISK.SYS**      Software device driver that turns the RAM 3000 Deluxe's memory into an electronic fast-access disk drive.

**ESPOOL.EXE**      Printer spooler program that lets you continue to use your computer while your printer is printing.

In order to have expanded memory in your system, the **EMM.SYS** EMS device driver must be installed. **EDISK.SYS** and **ESPOOL.EXE** are additional programs that you may want to install.

## Section 4 Summary

- 4.1 EMS Device Driver (**EMM.SYS**)
- 4.2 RAM Disk Device Driver (**EDISK.SYS**)
- 4.3 Print Spooler (**ESPOOL.EXE**)

## 4.1 EMS Device Driver (**EMM.SYS**)

Expanded memory did not exist when your PC and its operating system (DOS) were invented. Because of this, DOS does not recognize and cannot use any expanded memory space defined on your memory expansion card. In order to

use expanded memory space, a special device driver program must be loaded each time you boot up the system. In addition, you need application programs which can utilize expanded memory space.

On the RAM 3000 Deluxe utility diskette, a software device driver called **EMM.SYS** allows you to access expanded memory space. This device driver conforms to the Lotus/Intel/Microsoft Expanded Memory Specification (LIM 4.0), which is capable of supporting up to 32MB of expanded memory.

## Installing the EMS Device Driver

Follow the instructions below to install the EMS Device Driver in your root directory.

### Note

**If you have already configured your RAM 3000 Deluxe as explained in Section 2.4: *Configuring With Software*, the EMS driver has already been installed and the CONFIG.SYS file modified.**

1. Insert the RAM 3000 Deluxe utility diskette into drive A and close the drive door. Copy the file **EMM.SYS** from this diskette to the root directory of your system disk (the disk used to boot up your computer). For example, if you boot up from the hard disk, type:

```
COPY A:\EMM.SYS C:\ [↵]
```

2. Most systems have a **CONFIG.SYS** file of "chores" which loads software device drivers each time the computer is booted up. To instruct the computer to load the expanded memory device driver, add the command line **DEVICE=EMM.SYS** to your **CONFIG.SYS** file. (Refer to *Appendix E: Creating a CONFIG.SYS File*.)

## EMS Device Driver Parameters

To customize the EMS Device Driver, parameters may be added to the **DEVICE=EMM.SYS** command line in your **CONFIG.SYS** file. Refer to *Appendix E: Creating a CONFIG.SYS File*, to add these parameters to the command line. The parameters are organized in the following format:

```
device=[\path\]emm.sys [/c] [pppp] [/h:nnn] [/x:xxxx-cccc] [/i:iiii-dddd] [/t]
```

**These parameters also apply to the EMM.LSY driver.****Note**

The values designated between the brackets '[' ]' are optional and may be omitted. DO NOT type in the '[' ] characters themselves.

- \path\** Defines the location of the subdirectory where the **EMM.SYS** program is stored. If you place the **EMM.SYS** program in your root directory, omit the **[path\]** option altogether.
- pppp** Tells **EMM.SYS** where to look for a valid page frame at a particular segment address. The page frame is the first address of the EMS mapping window. Valid **[pppp]** values are C400, C800, CC00, D000, DC00, and E000 (Hex). For most users, C400 (default value if the **[pppp]** parameter is not specified) is fine and this parameter is not needed.
- /c** Instructs **EMM.SYS** to chain interrupt vector 67 (Hex). This parameter is needed in case another driver in the system also uses interrupt vector 67 (Hex). For example, if an AST PCnet II network adapter card is installed in addition to the RAM 3000 Deluxe, you must use this parameter.
- /h:nnn** Informs **EMM.SYS** of the maximum number of expanded memory handles. Valid **[:nnn]** values range from 64 through 255. If you omit this parameter, the number of expanded memory handles is 64. If you increase this value, please note that a smaller amount of base memory is available for other uses.
- /x=xxxx-cccc** Specifies an area of memory segment addresses (between A000 and FFFF) that you do not want **EMM.SYS** to use as a "window" to access expanded memory. Use **[xxxx]** to specify the starting segment address in hexadecimal, and **[cccc]** to specify the ending segment address in hexadecimal. For example, if you install a network adapter card that uses segment addresses CC00-CFFF, type this parameter as **/x:CC00-CFFF**.

- /i=iiii-dddd** Specifies an area of memory segment addresses (between A000 and FFFF) that you want **EMM.SYS** to use as an extra “window” to access expanded memory in addition to the existing “windows.” Use [iiii] to specify the starting segment address in hexadecimal, and [dddd] to specify the ending segment address in hexadecimal. For example, if you do not plan to install an EGA or VGA graphics card, you can use segment addresses A000-AFFF, type this parameter as **/i:A000-AFFF**.
- /t** Retrieves detailed information about the driver. This option was originally designed as a remote debugging tool for the EMS driver developers.

## EMS Device Driver Examples

### **DEVICE=EMM.SYS**

This **EMM.SYS** command line is the basic one and would be sufficient in most cases for one RAM 3000 Deluxe installed.

### **DEVICE=EMM.SYS /X:C000-CC00 /I:A000-AFFF**

This **EMM.SYS** command line excludes memory segment addresses C000-CC00 and includes memory segment addresses A000-AFFF for placement of an extra “window” to access expanded memory besides the normal window.

### **DEVICE=\UTIL\EMM.SYS /C /H:128**

This **EMM.SYS** command line finds the **EMM.SYS** file in the **\UTIL** Subdirectory, enables interrupt vector 67 (Hex) chaining, and defines 128 available expanded memory handles.

## 4.2 RAM Disk Device Driver (EDISK.SYS)

On the RAM 3000 Deluxe utility diskette, a software device driver called **EDISK.SYS** allows you to set aside part of your computer's base, extended, or expanded memory for a RAM disk. The RAM disk is recognized by DOS just as if it were a hard drive or a floppy drive: you can create directories and sub-directories on it, and transfer and save your files just as you would do on any disk. DOS assigns the next available drive letter to each RAM disk. For example, your first RAM disk becomes drive C: if you do not have a hard disk or drive D: if you do have one.

The RAM disk has the following advantages:

- The access time is extremely fast because there are no mechanical access procedures.
- The RAM disk can be of any size. It can be made larger or smaller, deleted and re-created, at will.
- You already have all the requisite hardware to create a RAM disk; there is nothing else to buy. If you don't want it any more, you can get rid of it at any time and not be out of your investment.

The RAM disk has the following disadvantages:

- None of the data in a RAM disk is permanently saved until it is stored on a real physical disk. The RAM disk consists of memory only, which is volatile. If you re-set your system or the power is interrupted (even accidentally), everything that was in the RAM disk is gone forever. But because the RAM disk so closely resembles a real storage device, it's easy to forget or overlook this fact.
- The portion of your memory that you devote to a RAM disk is unavailable for any other use.

Before you install the RAM disk device driver, identify the memory types (base, extended, or expanded) that exist in your system and decide where you want to install a RAM disk. For an explanation of the different types of memory available in your system, refer to *Appendix A: Memory Basics*.

**EDISK.SYS** allows you to define as many RAM disks as you want, in one or more memory types. You are limited only by your system's total memory capacity.

Each RAM disk requires a separate line defined in the **CONFIG.SYS** file. Also, each RAM disk defined can only use one type of memory. You cannot define a single RAM disk to split over several memory types. However, you can define two or more RAM disks within one type of memory, as long as the RAM disks fit within the computer's limit for that type of memory.

## Installing the RAM Disk Driver

These installation instructions create one default RAM disk in base memory. Refer to the following sections on RAM disk parameters and examples to customize your RAM disk.

1. Insert the RAM 3000 Deluxe utility diskette in drive A and close the drive door. Copy the file **EDISK.SYS** from this diskette to the root directory of your system disk (the disk used to boot up the computer). For example, if you boot up from a hard disk, type:

```
COPY A:\EDISK.SYS C:\
```

2. Most systems have a **CONFIG.SYS** file of "chores" which loads software device drivers each time the computer is booted up. To instruct the computer to load the RAM disk device driver, add the command line **DEVICE=EDISK.SYS** to your **CONFIG.SYS** file. (Refer to *Appendix E: Creating a CONFIG.SYS File*.)

To remove the RAM disk, remove the **DEVICE=EDISK.SYS** command line from the **CONFIG.SYS** file. The next time you re-boot, the RAM disk will no longer exist, and that portion of memory previously occupied by the RAM disk will be available for other uses.

### Note

If you use EMS memory to install the **EDISK**, the **EMM.SYS** command line must precede the **EDISK.SYS** command line in the **CONFIG.SYS** file.

## RAM Disk Parameters

To customize the RAM disk, parameters may be added to the **DEVICE=EDISK.SYS** command line in your **CONFIG.SYS** file. The parameters are organized in the following format:

**device=**[\path\]edisk.sys [bbb] [sss] [ddd] [/e[:n]] [/x] [/l]

The values between the '[' symbols are optional and may be omitted. DO NOT type in the '[' symbols themselves.

- \path\** Defines the location of the subdirectory where the **EDISK.SYS** device driver is stored. If you place the **EDISK.SYS** device driver in the root directory, you can omit this parameter.
- bbb** Defines the buffer size, or capacity, of the RAM disk. If this parameter is omitted, the default buffer size is 128KB. For a larger or smaller RAM disk, enter the appropriate size in KB. The smallest RAM disk size is 1KB; the largest RAM disk size is the total available memory of a memory type.
- If the RAM disk resides in base memory, at least 64KB of base memory must be free for DOS. The **EDISK.SYS** device driver checks for 64KB of free base memory when it creates the RAM disk. If the specified buffer size leaves less than 64KB for base memory, it reduces the buffer size. If this still leaves less than 64KB free, **EDISK.SYS** cannot create the RAM disk.
- sss** Defines the sector size. If this parameter is omitted, the sector size is 512 bytes. If this parameter is included, the valid choices are 128, 256, and 512.
- ddd** Defines the maximum number of entries in the root directory of the RAM disk. If this parameter is omitted, the maximum number of entries is 64. If this parameter is included, the valid values range from 2 through 512.
- /e[:n]** Informs **EDISK.SYS** to create the RAM disk in AT-only extended memory. The value [:n] represents the number of sectors to transfer in and out of extended memory at one time. If you omit [:n], the default transfer size is 8. If you include [:n], the valid values range from 1 to 8.

DO NOT put the [/e:n] and the [/x] parameters on the same command line.

**/x** Informs EDISK to locate the RAM disk in expanded (EMS) memory.

DO NOT put the [/e:n] and the [/x] parameters on the same command line.

**/l** Allows the RAM disk to be installed with no volume label, which frees an extra 32 bytes of base memory for other uses.

## RAM Disk Driver Examples

### DEVICE=EDISK.SYS

This example looks up the **EDISK.SYS** driver in base memory, then creates the default RAM disk in base memory. The buffer size is 128KB, the sector size is 512 bytes, and the maximum number of entries in the root directory is 64.

### DEVICE=\EVEREX\EDISK.SYS 512 /X

This example looks up the **EDISK.SYS** driver in the **\EVEREX** subdirectory, then creates a 512KB RAM disk in expanded memory.

### DEVICE = \EVEREX\EDISK.SYS 3072 512 256 /E:6

This example looks up the **EDISK.SYS** driver in the **\EVEREX** subdirectory, then creates a RAM disk with a buffer of 3072KB, a sector size of 512 bytes, with the maximum number of root directory entries at 256. It creates the RAM disk in extended memory, and the memory block transfer size is 6.

## 4.3 Print Spooler (ESPOOL.EXE)

A print spooler program allows you to continue using your computer (i.e. entering data, writing letters, etc.) while your printer is printing. The print spooler program is a great way to save time since you no longer have to wait for your printer to stop printing before you can use your system again.



There is a print spooler program called **ESPOOL.EXE** on the RAM 3000 Deluxe utility diskette. This program allows your computer to do other tasks while the printer is printing. **ESPOOL.EXE** installs a print buffer of any size from 1KB to 15360KB in any type of memory (base, extended, or expanded), and sends the contents of the print spooler to any parallel or serial port in your computer.

## Installing the Print Spooler

The following instructions install a default print spooler in base memory, is 64KB in size, and sends the contents of the spooler to parallel port LPT1:

1. Insert the RAM 3000 Deluxe utility diskette in disk drive A. Copy the print spooler program **ESPOOL.EXE** from this diskette to the root directory of your system disk. At the DOS prompt type:

```
COPY A:\ESPOOL.EXE C:\ [↵]
```

2. At the DOS prompt, type:

```
CD\ [↵]
ESPOOL [↵]
```

The print spooler is now loaded into your system and ready to use.

## Print Spooler Parameters

To customize the print spooler, parameters may be added to the **ESPOOL** command line. The parameters are organized in the following format:

```
[path]\espool [/b:bbb] [/e] [/x] [/p:n] [/s:n[,b,p,d,s,h]] [/r]
```

The values between the '[' symbols are optional and can be omitted. DO NOT type the '[' characters themselves.

**\path\** Defines the subdirectory where the **ESPOOL.EXE** program is located. If **ESPOOL.EXE** is located in the root directory, you can omit this parameter.

- /b:bbb** Defines the size of the print spooler. Valid [:bbb] sizes range from 1KB through 15360KB. If you omit this parameter, the spooler size is 64KB.
- /e, /x** Creates the print spooler in either extended memory or expanded memory. Omitting these parameters results in the print spooler located in base memory. Use the [/e] parameter if you want the spooler in extended memory, or use the [/x] parameter if you want the spooler in expanded memory.
- DO NOT put [/e:n] and the [/x] parameters on the same command line.
- /p:n** Defines which parallel port the contents of the print spooler are sent to. If this parameter is omitted, the print spooler sends its contents to parallel port LPT 1. If this parameter is included, [/p:1] sends the contents to the LPT 1 parallel port (port address 3BC-3BF), [/p:2] sends the contents to LPT 2 parallel port (port address 378-37F), and [/p:3] sends the contents to LPT 3 parallel port (port address 278-27F). If only one parallel port exists in your system, use [/p:1] or omit this parameter altogether.
- /s:n** Defines which serial port the contents of the print spooler are sent to. If this parameter is included, [/s:1] sends the contents to the COM 1 serial port (port address 3F8-3FF), [/s:2] sends the contents to the COM 2 serial port (port address 2F8-2FF), [/s:3] sends the contents to the COM 3 serial port (port address 3E8-3EF), and [/s:4] sends the contents to the COM 4 serial port (port address 2E8-2EF).
- ,b,p,d,s,h** Represents the options of the [/s:n] parameter. These parameters are: b (which sets the baud rate; the valid values are 110, 150, 300, 600, 1200, 2400, 4800, and 9600), p (which sets the parity bit; the valid values are n for none, o for odd, and e for even), d (which sets the number of data bits; valid values are 5,6,7, or 8), s (which sets the stopbit; valid values are 1 and 2), and h (which enables the XON/XOFF handshaking protocol to prevent the sending of spooler contents to a serial printer if the serial printer is not ready to accept commands and spooler data).

/r Checks the status of the print spooler. After the **ESPOOL.EXE** print spooler is loaded, type the following:

```
ESPOOL /R [↵]
```

The screen responds with a print spooler status message.

## Print Spooler Examples

```
ESPOOL /B:32 /P:2
```

This enables a 32KB print spooler, with its contents sent to parallel port LPT 2.

```
\UTIL\ESPOOL /B:256 /X /P:2
```

This looks for the **ESPOOL.EXE** program in the **\UTIL** subdirectory, then enables a 256KB print spooler in expanded memory, and sends its contents to parallel port LPT 2.

```
\EVEREX\ESPOOL /B:1024 /E /S:2,1200,E,7,1,H
```

This looks for the **ESPOOL.EXE** program in the **\EVEREX** subdirectory, then enables a 1024KB print spooler in extended memory, with its contents sent to serial port COM 2. This **ESPOOL.EXE** command line tells the COM 2 serial port to use 1200 baud transfer rate, even parity, 7 databits and 1 stopbit. The XON/XOFF handshaking protocol is enabled.

# Troubleshooting

---

This section gives you solutions to minor problems that you may encounter when installing or using the RAM 3000 Deluxe. The quick checkout and reference table provide answers for some common problems. Technical support procedures are included in case you require additional assistance.

If you encounter any problems while using your RAM 3000 Deluxe, first refer to this User's Guide, then go through the Quick Checkout, and finally go through the troubleshooting table (Table 5-1).

This section explains how to locate and resolve some simple problems that might be encountered with the RAM 3000 Deluxe. Before reading this troubleshooting section, try rereading this manual and rechecking the installation procedures. Technical support procedures are included in case additional assistance is required.

## Section 5 Summary

- 5.1 Quick Checkout
- 5.2 How to Get Help

## 5.1 Quick Checkout

- Make sure that the DRAM chips are properly installed on the RAM 3000 Deluxe.
- Make sure the RAM 3000 Deluxe is correctly configured.
- Make sure the RAM 3000 Deluxe is properly seated in an expansion slot.
- Verify that all of the DRAM chips installed are working properly by testing them with the diagnostics test on the **INST159.EXE** utility program located on the RAM 3000 Deluxe utility diskette.

- Make sure the EMM.SYS EMS device driver is installed if the RAM 3000 Deluxe is configured to have expanded memory (EMS).

If the problem still persists after trying the above suggestions, please refer to the troubleshooting table in Table 5-1.

**Table 5-1** ➤ **Troubleshooting Table**

SYMPTOM	SOLUTION
<p>You cannot access extended memory defined on the RAM 3000 Deluxe</p> <p>The system does not boot properly when the RAM 3000 Deluxe is configured to upgrade base memory.</p> <p>You have difficulty in accessing the expanded memory on the RAM 3000 Deluxe.</p>	<ul style="list-style-type: none"> <li>• Normally, base memory must be fully filled to 640K before you can have any extended memory.</li> <li>• Make sure the starting address of the extended memory on the RAM 3000 Deluxe is equal to the amount of extended memory already in your system (e.g. if you have 2MB of extended memory already installed in your system, set memory starting address at 3072K (300000H); see <i>Section 2.6</i> for instructions on configuring the RAM 3000 Deluxe's memory starting address).</li> <li>• Run the AT SETUP program to configure the system so it recognizes the memory on the RAM 3000 Deluxe.</li> <li>• The chips on Bank 0 and Bank 1 (which are used for base memory upgrading) are either improperly installed or defective.</li> <li>• Reconfigure the RAM 3000 Deluxe for EMS as explained in <i>Section 2.4</i> or <i>Section 2.5</i>.</li> <li>• Reinstall the EMM.SYS expanded memory device driver as explained in <i>Section 4.1</i>.</li> </ul>

## 5.2 How To Get Help

### Contacting Everex Technical Support

If you have read this manual, checked all settings, and are still having problems, we recommend that you first contact your dealer. If your dealer cannot solve the problem, you can get technical support from the Everex technical support department at (415) 498-1115. In order to simplify troubleshooting, gather the following information before placing your call:

- This manual (include the version number)
- Description of your problem
- Place of purchase
- Date of purchase
- Serial number of the RAM 3000 Deluxe board
- Brand name and model of the computer you are using
- Monitor make and model
- Hard disk drive(s) make and capacity
- Memory configuration, including the amount and type
- List of additional peripheral products in your computer
- Name and version number of the operating system you use
- Contents of your **CONFIG.SYS** file
- Contents of your **AUTOEXEC.BAT** file
- Any facts or circumstances that may be relevant to the problem

Try to be near your system and have your system open when you call in order to follow the technician's suggestions quickly and easily.

## Returning Merchandise For Repair

If the RAM 3000 Deluxe board requires repair, you must contact the Everex technical support department at (415) 498-1115 for a Return Merchandise Authorization (RMA) number. In addition to your RMA number, please include the following information:

- Serial number of your RAM 3000 Deluxe Board
- Date and place of purchase
- Copy of your sales receipt

The above information will help us expedite your repair.

# Memory Basics

---

This appendix provides an introduction to basic concepts of memory. It also explains how memory is allocated on the AT and highlights the locations of base, extended and system reserved memory.

## Appendix A Summary

- A.1 Introduction to Base, Extended, and Expanded (EMS) Memory
- A.2 AT Memory Space

## A.1 Introduction to Base, Extended, and Expanded (EMS) Memory

The RAM 3000 Deluxe is designed to provide up to 3MB of extended memory for AT machines. In addition, you can address up to 3MB of memory on the RAM 3000 Deluxe as expanded memory under the Lotus/Intel/Microsoft Expanded Memory Specification. You can set this card to upgrade base memory to the 640 KB (9FFFFH) base memory address limit imposed by DOS. If you are not familiar with the distinction between base, extended, and expanded memory, refer to the following explanations.

**BASE MEMORY**—memory addresses from 0K to 640K (00000H-9FFFFH). This memory area is used by DOS for programs and data.

**EXTENDED MEMORY**—memory addresses from 1024K to 16384K (100000H-FFFFFFH). The AT or compatible uses this area to store data and programs. DOS does not recognize this memory space, but certain programs can use this memory space (notably the RAM disk and the OS/2 disk operating system).

**EXPANDED MEMORY (EMS)**—memory (developed by a joint project of Lotus, Intel and Microsoft) that uses a bank switching technique so specially-written DOS programs can overcome the DOS imposed 0K-640K (00000-9FFFFH) memory addressing limitation for program data. The EMM.SYS



EMS Device Driver is required to run EMS as explained in *Section 4.1: EMS Device Driver (EMM.SYS)*. The EDISK.SYS RAM disk utility can also use this memory space as explained in *Section 4.2: RAM Disk Driver (EDISK.SYS)*. For more information on Expanded memory, refer to *Appendix B: Expanded Memory (EMS) Technical Reference*.

On the RAM 3000 Deluxe, expanded memory has two benefits:

1. It allows program data to be as large as 32MB in size when you install several cards that meet this memory specification in the computer.
2. Some application programs written to take advantage of the EMS standard can run from expanded memory.

**Note**

**You should not change memory at addresses 640K to 1024K (A000H-FFFFH). This area is reserved for programs used by the system in order for the computer to function. (It is also used as the I/O port address for expanded memory.) A similar reserved memory space is located at the memory addresses of 16256K to 16384K (FE000H-FFFFFFH).**

## A.2 AT Memory Space

Figure A-2 shows how the AT allocates memory and highlights the locations of base, extended and system reserve memory.

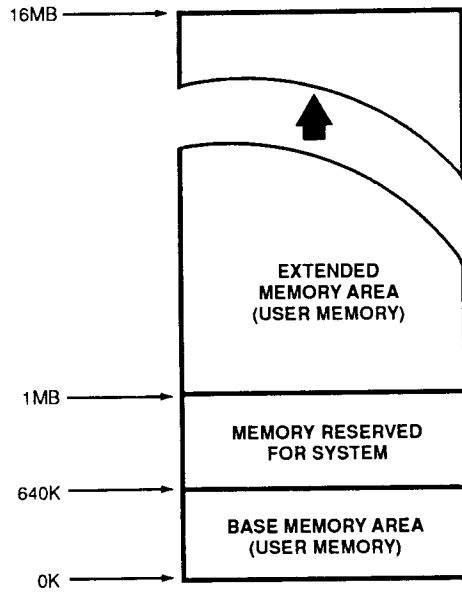

AT Memory Space

◀ Figure A-2

# Expanded Memory (EMS) Technical Reference

---

This appendix provides an overview of how expanded memory works within your system.

Application programmers writing software for the EMS mode on the RAM 3000 Deluxe should refer to the Lotus/Intel/Microsoft specification (LIM 4.0). Use of this document will facilitate portability to all EMS compatible expanded memory cards.

## Appendix B Summary

- B.1 Expanded Memory (EMS) Definition
- B.2 Theory of Paging
- B.3 Mapping Registers
- B.4 EMS I/O Port Address Selections

## B.1 Expanded Memory (EMS) Definition

Expanded memory is memory that uses a paging technique so specially written DOS programs can overcome the DOS-imposed 0KB-640KB (00000H-9FFFFH) memory addressing limitation for program data. Up to 32MB total of expanded memory can be supported by the software driver EMM.SYS. For each RAM 3000 Deluxe board installed, up to 3MB of expanded memory is supported.

## B.2 Theory of Paging

“Paging” is a method of memory mapping that allows a computer to utilize more memory than it can physically address. EMS uses such a method by dividing the physical memory on an EMS board into pages of 16KB each. These pages are subsequently mapped into a 16KB address space of the CPU; this address space is known as a window. By varying the values of the mapping registers, any one of the 16KB physical memory pages on the EMS board can be mapped into a 16KB window. Figure B-1 shows how the mapping is completed on the RAM 3000 Deluxe.

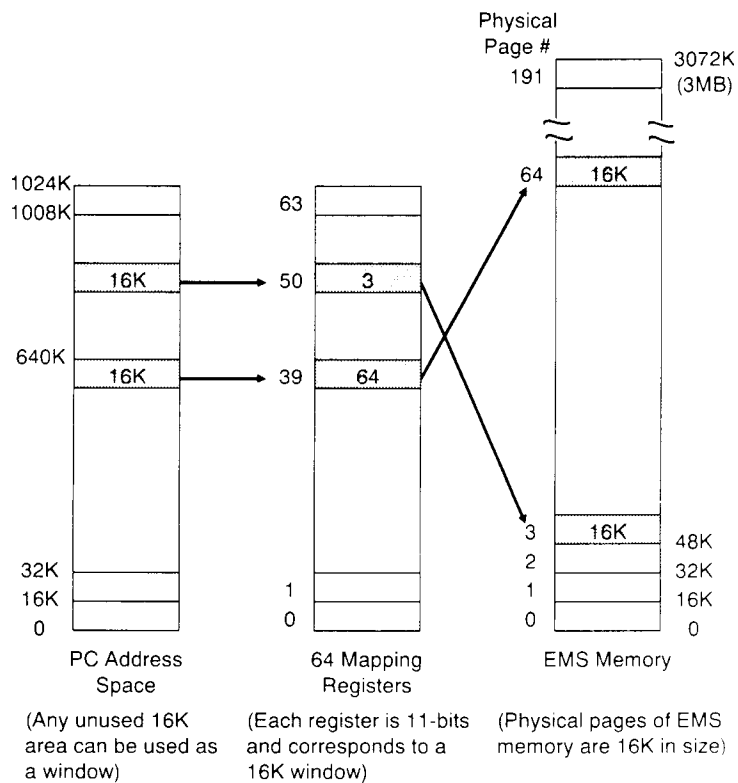

Figure B-1 ► EMS Addressing

## B.3 Mapping Registers

Each RAM 3000 Deluxe has 64 page-mapping registers of 11 bits each. Each register corresponds to a 16KB window in the 0KB-1024KB PC address space.

Every page of EMS memory is 16KB in size. By setting the mapping registers to values from 0 to 1024, one of the 16KB pages in an EMS memory board can be mapped via the page mapping register.

With bits 0-9 (LSB) accounting for the 0 to 1024 range, the last bit (MSB) in the mapping register can be used to enable or disable a particular page. Each mapping register can handle up to 16MB of EMS memory (16KB x 1024 = 16MB). Figure B-2 represents how the contents of the mapping registers can be used:

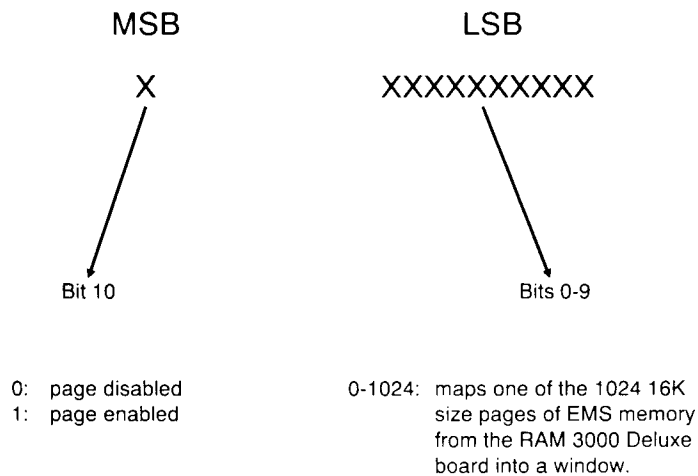

Mapping Registers

◀ Figure B-2

## B.4 EMS I/O Port Address Selections

EMS uses I/O ports to set up mapping information. These I/O ports are selectable and a number of I/O ports have been reserved for EMS memory. Table B-1 lists the port addresses reserved for EMS memory.

Table B-1 > Port Addresses Reserved for EMS Memory

I/O PORT
02X8
42X8
82X8
C2X8
02X9
42X9
82X9

For each port address, X is the variable selected by DIP switch SW1, positions 1-4 on the RAM 3000 Deluxe. In theory, SW1 can select X for 0 to F; but in order to avoid conflicts with other I/O devices, the Everex EMS device driver (EMM.SYS) will accept only these X values:

0, 1, 5, 6, A, B, E

# Interrupt Vector 67 (Hex)

---

This appendix discusses how to resolve a conflict that occurs between your RAM 3000 Deluxe and other cards that also use Interrupt Vector 67 (Hex), such as the AST PCnet II board.

## Appendix C Summary

### C.1 Conflict With Interrupt Vector 67 (Hex)

## C.1 Conflict With Interrupt Vector 67 (Hex)

If you enable the RAM 3000 Deluxe for EMS mode and also install the AST PCnet II network adapter board, a software conflict will occur involving the use of the interrupt vector 67 (Hex). Both the **EMM.SYS** expanded memory device driver and the AST PCnet II board use this interrupt vector (other hardware and software applications may use this interrupt vector also).

To ensure the RAM 3000 Deluxe and the PCnet II boards will work together in the same system, include the `/c` parameter to the **EMM.SYS** command line in your **CONFIG.SYS** file. This parameter instructs **EMM.SYS** to chain interrupt vector 67 (Hex) so that several applications can share interrupt vector 67 (Hex). (Refer to *Section 4.1: EMS Device Driver (EMM.SYS)* for information on **EMM.SYS** parameters.)

If you define any special applications in expanded memory space that require a driver in the **CONFIG.SYS** file (e.g. RAM disks and disk caching space), be sure the command line for the expanded memory application device driver comes after the **EMM.SYS** command line in your **CONFIG.SYS** file.

Note

# For Extended Memory Users

---

This appendix discusses how to configure and test your RAM 3000 Deluxe if you plan to use the RAM 3000 Deluxe with an extended memory only operating system such as OS/2 and Xenix.

## Appendix D Summary

### D.1 Extended Memory Operating Systems

## D.1 Extended Memory Operating Systems

If you plan to use the RAM 3000 Deluxe in conjunction with an extended memory only operating system such as OS/2 and Xenix, the **INST159.EXE** configuration and diagnostic program on the RAM 3000 Deluxe utility diskette is executed in the following manner:

1. Bootup your system with a PC-DOS or MS-DOS Version 3.0 or higher system diskette in drive A.
2. Replace the system diskette with the RAM 3000 Deluxe utility diskette and run the **INST159.EXE** program to configure your board as explained in *Section 2.4: Configuring With Software*.
3. Install your board as explained in *Section 3.2: Installing the RAM 3000 Deluxe*.
4. Test your board as explained in *Section 3.3: Testing the RAM 3000 Deluxe*.
5. Reboot your system with the appropriate operating system (e.g. OS/2 and Xenix).



This will ensure that the RAM 3000 Deluxe board will work properly when running extended memory programs.

# Creating a CONFIG.SYS File

---

If you wish to create or modify your CONFIG.SYS file, the following instructions will help you use the DOS COPY CON command.

## Appendix E Summary

### E.1 CONFIG.SYS File

#### E.1 CONFIG.SYS File

1. Make sure you are in the root directory of your system disk. At the DOS prompt type:

```
CD\ [↵]  
TYPE CONFIG.SYS [↵]
```

If a message *File not found* appears, go on to step 2; if one or more command lines appear, copy on a separate sheet of paper, the line(s) exactly as they appear on your screen. You will have to re-enter these lines in step 2.

---

**The following step will overwrite any existing CONFIG.SYS file.**

---

**Caution**

2. At the DOS prompt type:

```
CD\ [↵]  
COPY CON CONFIG.SYS [↵]
```

Add any necessary command lines (e.g. DEVICE=EMM.SYS) and include any additional parameters. Press the [↵] key after each command line. If you wrote down the contents of a previous CONFIG.SYS file, type the lines back in after the line you just added.

3. To save the new CONFIG.SYS file, press:

[F6]

[↓]

4. To confirm the new CONFIG.SYS file, type:

CD\

[↓]

TYPE CONFIG.SYS

[↓]

This command will list the contents of your CONFIG.SYS file.

5. Reboot your system.

# Glossary

---

## A

**Adapter** An electronic device, generally a card or board, which acts as an interface between two pieces of hardware. For example, the Everex Micro 8000 Memory Expansion Board which adds additional memory to your PS/2.

**Address** A number used to identify and reference a particular memory or port location. Each memory or port location is assigned and referenced with a unique address.

## B

**Bank Switching** The computer's ability to access more memory than the computer actually allows. This technique is used for expanded memory (see Expanded Memory)

**Base Memory** Computer memory addresses of 0KB-640KB (00000H-9FFFFH). Base memory is the memory addresses used by DOS for programs and data.

**Bit** A measure of memory, Bits (short for Binary Digits) are the smallest unit of measure that computers can work with.

**Bootup** A term that means to start or restart the computer. There are two specific types of bootup: cold boot and warm boot. A cold boot means that you have turned on the computer using the on/off switch. A warm boot is activated by simultaneously depressing the [Ctrl]-[Alt]-[Del] keys when the computer is operating.

**Byte** Eight Bits.

## C

**Configuration** The way a system, board, or device is set.

**CONFIG.SYS File** A file that provides DOS with information about the kinds of hardware attached to your computer. Whenever you turn on your computer or reboot it, DOS searches your system's root directory for the CONFIG.SYS file. If DOS finds one, it reads the commands from the file and adapts to your hardware.

## D

**Device Driver** A program loaded during the bootup process that allows DOS to access special hardware that DOS does not normally support (RAM disks, expanded memory, etc.).

**DOS (Disk Operating System)** An operating system for IBM computers and compatibles.

**DRAM (Dynamic Random-Access Memory)** RAM which requires electronic refresh cycles every few milliseconds in order to preserve data.

## E

**EDISK.SYS RAM Disk Driver** A software device driver that allows you to set aside part of your computer's base, extended, or expanded memory for a RAM disk.

**EMM.SYS EMS Device Driver** A software device driver that allows you to access expanded memory space.

**EMS (Expanded Memory Specification)** See Expanded Memory

**EMS IO Port Address** See I/O Port Address.

**ESPOOL.EXE** A program which allows your computer to do other tasks while the printer is printing. It installs a print buffer of any size from 1KB to 15360 KB in any type of memory, and sends the contents of the print spooler to the designated parallel or serial port.

**Expanded Memory** Memory (developed by a joint project of Lotus, Intel and Microsoft) that uses a bank switching technique (see **bank switching**) so specially written DOS programs can overcome the DOS-imposed 0K-640K (00000-9FFFFH) memory addressing limitation for program data.

**Expansion Slot** A connector on the system board that accepts add-in cards.

**Extended Memory** Memory addresses from 1024K to 16384K (100000H-FFFFFFH). This area can be used by the PS/2 to store data and programs. DOS does not recognize this memory space, but certain programs can use this memory space.

## H

**Hexadecimal** Base 16 notation of numbering. Hexadecimal digits are regularly used to indicate memory amounts and memory addresses

## I

**I/O Port Address (Input/Output)** An I/O Port Address corresponds to an electrical connection that the boards in your computer use to communicate with the processor or brain of the computer. Although it permits data to flow between board and processor, the I/O address has no relationship to the expansion slot where the board resides.

## K

**K or KB** Kilobyte.

**Kilobyte** A unit of measurement for data storage equal to 1,024 bytes.

## M

**MB** Megabyte.

**Megabyte** A unit of measurement for data storage equal to 1,048,576 bytes.

## P

**Page Frame** A series of memory addresses used as an area to access expanded memory.

**Parameter** An option or setting specified by the user as part of a command format.

**Populating** The process of adding memory chips to your RAM 3000 Deluxe.

**Port Address** See I/O Port Address.

**Print Spooler** An area of memory used to store and send data to a printer while the computer performs other tasks.

## R

**RAM (Random Access Memory)** Memory that can be written to and read from. Information is lost when the computer is turned off.

**RAM Disk** An electronic simulation in RAM of a disk drive.

**Reboot** Restarting the operating system. Press the Alt-Ctrl-Del key simultaneously.

**Return Merchandise Authorization (RMA)** An authorization from Everex Technical Support which allows you to return your merchandise for repair.

**ROM (Read-Only Memory)** Memory that can only be read from. This type of memory is used to store permanent data.

# Warranty

---

## LIMITED WARRANTY ON EVEREX COMPUTER PRODUCTS (Valid only in the U.S.A.)

Everex Systems, Inc. ("Everex") warrants to the original customer purchaser that this Everex computer product shall be free from defects in materials and workmanship for a period of one (1) year from the original date of purchase. At its option, Everex will repair or replace at no charge any Everex product which proves to be defective within such warranty period. This limited warranty shall not apply if the Everex product has been damaged by unreasonable use, accident, negligence, service, or modification by anyone other than an Everex Factory-Authorized Service Center, or by any other causes unrelated to defective materials and workmanship.

The original consumer purchaser must return the Original Registration Owner Card as a condition precedent to warranty coverage and performance. To receive in-warranty service, a defective product must be delivered to an Everex Factory-Authorized Service Center no later than one (1) week after the end of the warranty period. The product must be accompanied by proof of date of purchase satisfactory to Everex and by a Return Merchandise Authorization (RMA) number issued by Everex. For an RMA number and the location of the nearest authorized service center contact Everex Systems, Inc., 48436 Milmont Drive, Fremont, CA 94538 (415) 498-1115 (Technical Support) or (415) 683-2230 (Customer Service). Purchasers must prepay all delivery costs or shipping charges to return any defective Everex product under this warranty policy. If you ship any such product, we suggest you package it securely (using the original packing materials if possible) and insure it for value, as Everex assumes no liability for any loss or damage occurring during shipment.

EXCEPT FOR THE EXPRESS WARRANTY STATED ABOVE, EVEREX MAKES NO OTHER WARRANTIES, WHETHER EXPRESSED OR IMPLIED, WITH RESPECT TO THIS EVEREX PRODUCT. ALL IMPLIED WARRANTIES, INCLUDING THOSE OF MERCHANTABILITY AND FITNESS FOR A PARTICULAR PURPOSE ARE LIMITED TO THE DURATION OF THE EXPRESS WARRANTY SET FORTH ABOVE.

The limited warranty set forth above constitutes the sole and exclusive remedy of the original consumer purchaser with respect to any defective Everex product and is in lieu of all other obligations or liabilities of Everex. In no event shall Everex be liable for any costs of procurement of substitute goods, loss of profits, or any consequential, incidental, and/or other damages of any kind resulting from a breach of any applicable express or implied warranty, breach of any obligation arising from breach of warranty or otherwise with respect to the manufacture and sale of any Everex product, whether or not Everex has been advised of the possibility of such loss or damage.

The provisions of the foregoing warranty are only valid in the United States of America. The limited warranty set forth above gives you specific legal rights and you may also have other rights which vary from state to state. Some states do not allow limitations on how long an implied war-



ranty lasts and/or do not allow the exclusion of incidental or consequential damages, so the limitations and exclusions set forth on the reverse side hereof may not apply to you.

**OUT OF WARRANTY REPAIR:** If your Everex computer product requires service other than under warranty, please contact Everex for available repair information.

**ALL EVEREX COMPUTER SOFTWARE IS SOLD ON AN "AS IS" BASIS WITHOUT WARRANTY OF ANY KIND.** The entire risk as to the quality and performance of such software is with the purchaser. Should such software prove defective following its purchase, the purchaser (and not the manufacturer, distributor, or retailer) assumes the entire cost of all necessary servicing or repair. Everex shall have no liability or responsibility to the original purchaser or any other person or entity with respect to any claim, loss, liability, or damage caused or alleged to be caused directly or indirectly by any Everex software. This disclaimer includes but is not limited to any interruption of services, loss of business or anticipatory profits, or any incidental, consequential, and/or other damages of any kind resulting from the purchase, use, or operation of any Everex software. Some states do not allow the limitation or exclusion of implied warranties or of incidental or consequential damages, so these limitations and exclusions concerning Everex software may not apply to you.

Every reasonable effort has been made to ensure that Everex product manuals and promotional materials accurately describe Everex product specifications and capabilities at the time of publication. However, because of on-going improvements and updating of Everex products, Everex cannot guarantee the accuracy of printed materials after the date of publication and disclaims liability for changes, errors, or omissions.

# License Agreement

---

**PLEASE DO NOT BREAK UTILITY DISKETTE SEALS AND OPEN THE SOFTWARE ENVELOPES *BEFORE* YOU READ THIS LICENSE AGREEMENT**

## **EVEREX SYSTEMS, INC. - SOFTWARE LICENSE AGREEMENT**

THIS SOFTWARE LICENSE AGREEMENT CONSTITUTES AN AGREEMENT BETWEEN YOU AND EVEREX SYSTEMS, INC. YOU SHOULD CAREFULLY READ THE FOLLOWING TERMS AND CONDITIONS BEFORE OPENING THIS ENVELOPE. BREAKING THE SEAL OR OTHERWISE REMOVING OR USING THE DISK(S) INSIDE INDICATES YOUR ACCEPTANCE OF THESE TERMS AND CONDITIONS. IF YOU DO NOT AGREE TO BE BOUND BY THE PROVISIONS OF THIS LICENSE AGREEMENT, YOU SHOULD PROMPTLY RETURN THE ENTIRE PRODUCT (INCLUDING ALL RELATED DOCUMENTATION) WITH THE ENVELOPE UNOPENED AND THE SEAL UNBROKEN, ACCOMPANIED BY PROOF OF DATE OF PURCHASE, TO THE PLACE WHERE YOU OBTAINED THEM.

### **Terms and Conditions**

- 1. GRANT OF LICENSE.** In consideration of payment of the License Fee, which was a part of the price you paid for this product, Everex (the "Licensor") grants to you (the "Licensee"), a non-exclusive right to use and display this copy of an Everex software program (hereinafter the "Software") on a single computer (i.e., with a single CPU) at a single location. If the single computer on which you use the Software is a multi-user system, the license herein granted covers all users on that single computer system. Everex reserves all rights not expressly granted to Licensee in this License Agreement.
- 2. OWNERSHIP OF SOFTWARE.** The license granted herein is not a sale of the original Software or of any copy of such Software. As Licensee, you own only the magnetic or other physical *media* on which the Software is originally or subsequently recorded or fixed. Everex retains title and ownership of the Software recorded on the original disk(s), as well as ownership of any subsequent copies of the Software, irrespective of the form of media on or in which the Software is recorded or fixed.
- 3. USE RESTRICTIONS.** As Licensee, you may use the Software only as expressly authorized in this License Agreement. You may physically transfer the Software from one computer to another provided that the Software is used on only one computer at a time. You may not: (i) electronically transfer the Software from one computer to another over a network; (ii) make the Software available through a time-sharing service, network of computers, or other multiple user arrangement; (iii) distribute copies of the Software or related written materials to any third party; or (iv) modify, adapt, translate, reverse engineer, decompile, disassemble, or prepare any derivative work based on the Software or any element thereof, without the express written consent of Everex.
- 4. COPY RESTRICTIONS.** The Software and accompanying written materials are copyrighted. Unauthorized copying and/or distribution of the Software and/or the related written materials is expressly forbidden. You may be held legally responsible for any copyright infringement that is caused, directly or indirectly, by your failure to abide by the terms of this License Agreement.

License

Subject to the terms of this License Agreement, and if not otherwise copy protected, you may make one copy of the Software for backup or archival purposes only. The copyright notice and any other proprietary notices which were included in the original Software must be reproduced and included on any such backup or archival copy.

5. **TRANSFER RESTRICTIONS.** The license herein granted is personal to you, the Licensee. You may not transfer the Software to anyone else, nor may you sell, lease, loan, sublicense, assign, or otherwise dispose of the Software without the express written consent of Everex, which consent may be granted or withheld at Everex's sole discretion.

6. **TERMINATION.** The license herein granted hereby will remain in effect until terminated. This license will terminate automatically without further notice from Everex in the event of the violation of any of the provisions hereof. As Licensee, you agree that upon such termination you will promptly destroy any and all copies of the Software which remain in your possession and, upon request, will certify to such destruction in writing to Everex.

7. **LIMITATION AND DISCLAIMER OF WARRANTIES.**

(A) THE SOFTWARE AND RELATED WRITTEN MATERIALS, INCLUDING ANY INSTRUCTIONS FOR USE, ARE PROVIDED ON AN "AS IS" BASIS, WITHOUT WARRANTY OF ANY KIND, EXPRESS OR IMPLIED. THIS DISCLAIMER OF WARRANTY EXPRESSLY INCLUDES, BUT IS NOT LIMITED TO, ANY IMPLIED WARRANTIES OF MERCHANTABILITY AND/OR OF FITNESS FOR A PARTICULAR PURPOSE. NO ORAL OR WRITTEN INFORMATION GIVEN BY EVEREX, ITS SUPPLIERS, DISTRIBUTORS, DEALERS, EMPLOYEES, OR AGENTS, SHALL CREATE OR OTHERWISE ENLARGE THE SCOPE OF ANY WARRANTY HEREUNDER. LICENSEE ASSUMES THE ENTIRE RISK AS TO THE QUALITY AND THE PERFORMANCE OF SUCH SOFTWARE. SHOULD THE SOFTWARE PROVE DEFECTIVE, YOU, AS LICENSEE (AND NOT EVEREX, ITS SUPPLIERS, DISTRIBUTORS, DEALERS OR AGENTS), ASSUME THE ENTIRE COST OF ALL NECESSARY CORRECTION, SERVICING, OR REPAIR.

(B) Everex warrants the diskette(s) on which the Software is recorded or fixed to be free from defects in materials and workmanship, under normal use and service, for a period of ninety (90) days from the date of delivery as evidenced by a copy of the applicable receipt. Everex hereby limits the duration of any implied warranties with respect to the diskette(s) to the duration of the express warranty. This limited warranty shall not apply if the diskette(s) have been damaged by unreasonable use, accident, negligence, or by any other causes unrelated to defective materials or workmanship.

(C) Everex does not warrant that the functions contained in the Software will be uninterrupted or error free and Licensee is encouraged to test the Software for Licensee's intended use prior to placing any reliance thereon.

(D) THE LIMITED WARRANTY SET FORTH ABOVE GIVES YOU SPECIFIC LEGAL RIGHTS AND YOU MAY ALSO HAVE OTHER RIGHTS WHICH VARY FROM STATE TO STATE. SOME STATES DO NOT ALLOW THE LIMITATION OR EXCLUSION OF IMPLIED WARRANTIES OR OF INCIDENTAL OR CONSEQUENTIAL DAMAGES. SO THE LIMITATIONS AND EXCLUSIONS CONCERNING THE SOFTWARE AND RELATED WRITTEN MATERIALS SET FORTH ABOVE MAY NOT APPLY TO YOU.

8. **LIMITATION OF REMEDIES.** Everex's entire liability and Licensee's exclusive remedy shall be the replacement of any diskette not meeting the limited warranty set forth in Subsection 7(B), above, which is returned to Everex with a copy of the applicable receipt within the warranty period. Any replacement diskette(s) will be warranted for the remainder of the original warranty period or thirty (30) days, whichever is longer.

9. **LIMITATION OF LIABILITY.** IN NO EVENT WILL EVEREX, OR ANYONE ELSE, INVOLVED IN THE CREATION, PRODUCTION, AND/OR DELIVERY OF THIS SOFTWARE PRODUCT BE LIABLE TO LICENSEE OR ANY OTHER PERSON OR ENTITY FOR ANY DIRECT OR OTHER DAMAGES, INCLUDING, WITHOUT LIMITATION, ANY INTERRUPTION OF SERVICES, LOST PROFITS, LOST SAVINGS, LOSS OF DATA, OR ANY OTHER CONSEQUENTIAL, INCIDENTAL, SPECIAL, OR PUNITIVE DAMAGES, ARISING OUT

OF THE PURCHASE, USE, INABILITY TO USE, OR OPERATION OF THE SOFTWARE, EVEN IF EVEREX OR ANY AUTHORIZED EVEREX DEALER HAS BEEN ADVISED OF THE POSSIBILITY OF SUCH DAMAGES. LICENSEE ACCEPTS SAID DISCLAIMER AS THE BASIS UPON WHICH THE SOFTWARE IS OFFERED AT THE CURRENT PRICE AND ACKNOWLEDGES THAT THE PRICE OF THE SOFTWARE WOULD BE HIGHER IN LIEU OF SAID DISCLAIMER. SOME STATES DO NOT ALLOW THE LIMITATION OR EXCLUSION OF LIABILITY FOR INCIDENTAL OR CONSEQUENTIAL DAMAGES SO THE ABOVE LIMITATIONS AND EXCLUSIONS MAY NOT APPLY TO YOU.

10. **UPDATES.** Everex, at its sole discretion, may periodically issue updates of the Software. Any such updates will be made available to Licensee, provided that Licensee prepays any applicable update fee.

11. **EXPORT RESTRICTIONS.** Licensee agrees not to export or re-export the Software and accompanying documentation (or any copies thereof) in violation of any applicable U.S. laws or regulations.

12. **ENTIRE AGREEMENT.** YOU, AS LICENSEE, ACKNOWLEDGE THAT: (i) YOU HAVE READ THIS ENTIRE AGREEMENT AND AGREE TO BE BOUND BY ITS TERMS AND CONDITIONS; (ii) THIS AGREEMENT IS THE COMPLETE AND EXCLUSIVE STATEMENT OF THE UNDERSTANDING BETWEEN THE PARTIES AND SUPERSEDES ANY AND ALL PRIOR ORAL OR WRITTEN COMMUNICATIONS RELATING TO THE SUBJECT MATTER HEREOF; AND (iii) THIS AGREEMENT MAY NOT BE MODIFIED, AMENDED, OR IN ANY WAY ALTERED EXCEPT BY A WRITING SIGNED BY BOTH YOURSELF AND EVEREX.

13. **SEVERABILITY.** In the event that any provision of this Agreement is held to be illegal or otherwise unenforceable, such provision shall be deemed to have been deleted from this Agreement, while the remaining provisions of this Agreement shall be unaffected and shall continue in full force and effect.

14. **GOVERNING LAW.** This Agreement shall be governed by the laws of the State of California and of the United States of America, excluding that body of law related to choice of laws.

# Index

---

## A

About jumpers and DIP switches, 2-3  
AST PCnet II, 4-3, C-1

## B

Bank switching, A-1  
Banks  
    See Memory banks  
Base memory, 4-5, 4-7, 4-10, A-1  
Base memory upgrading, 2-7, 5-2

## C

Checklist, 1-2  
Clock speed, 2-10  
CONFIG.BAK file, 2-7  
CONFIG.SYS file, 2-7, 4-2, 4-6, C-1, E-1 - E-2  
Configuration, 2-1 - 2-20  
    Two or more boards, 2-7  
    With software, 2-4, 2-9  
    Without software, 2-8 - 2-9  
Configuration file, 2-6 - 2-7  
Contiguous memory, 2-3, 2-13 - 2-14  
COPY CON command, E-1  
CS8220 CHIPSet, 2-17

## D

Default settings, 2-2  
Device driver

    See also EMS device driver

    See also RAM disk

Diagnostic program, 3-7, 5-1  
DIP switch, 2-3, 2-6, 2-8  
    SW1, 2-2, 2-8, 2-11, B-4  
    SW2, 2-2, 2-8, 2-13, 3-2  
    SW3, 2-3, 2-8, 2-16, 2-19  
DIP switch functions, 2-8  
DIP switch settings, 2-9  
DOS, A-1  
DRAM chip, 1-2, 2-2, 2-8, 2-10, 2-13, 3-1, 5-1 - 5-2

## E

EDISK.SYS  
    See RAM disk driver  
EMS  
    See also Expanded memory  
EMS data transfer, 2-3, 2-11  
EMS device driver, 4-1, 5-2, A-2, B-4  
    # of expanded memory handles, 4-3  
    CONFIG.SYS file, 4-2  
    EMM.SYS, 4-1, 5-2  
    EMML.SYS, 4-1  
    Examples, 4-4  
    Installation, 4-2  
    Parameters, 4-2, C-1  
    Path, 4-3  
    Segment addresses, 4-3  
EMS I/O port address, 2-2, 2-8, 2-11, B-4  
EMS Technical Reference, B-1 - B-4  
EMS transfer mode, 2-8, 2-16

**ESPOOL.EXE**

See Print spooler

Everex technical support. 5-3 - 5-4

**Examples**

EMS device driver (EMM.SYS), 4-4

Print spooler (ESPOOL.EXE), 4-11

RAM disk (EDISK.SYS), 4-6, 4-8

Expanded memory. 2-11, 4-1, 4-3, 4-5, 4-8, 4-10, 5-2, A-1, B-3

Expanded memory definition, B-1

Expanded memory handles, 4-3

Expansion slot, 3-4, 5-1

Extended memory, 4-5, 4-7, 4-10, 5-2, A-1, D-1 - D-2

Extended memory operating system, D-1

**F**

Features, 1-1

**G**

Getting started, 1-1 - 1-6

**H**

Hardware installation, 3-1 - 3-8

Help, 5-3

Hexadecimal, 4-3

**I**

INST159.EXE program, 2-6

**Installation**

DRAM chips, 3-1

EMS device driver, 4-2

Hardware, 3-1 - 3-8

Print spooler, 4-9

RAM 3000 Deluxe, 3-4

RAM disk, 4-6

Software, 4-1 - 4-12

Installation summary, 1-5 - 1-6

Interrupt, 4-3

Interrupt vector 67, C-1

**J**

Jumper, 2-3, 2-6

Functions, 2-8

Settings, 2-9

Shunt, 2-3, 2-10

W1, 2-2, 2-8, 2-10, 3-1

W2, 2-2, 2-8, 2-10

**L**

Lotus/Intel/Microsoft Expanded Memory Specification, 4-2, A-1, B-1

LSB, B-3

**M**

Manual conventions, 1-4

Mapping registers, B-2 - B-3

**Memory**

See also Base memory

See also Extended memory

Memory banks, 2-6, 2-8, 2-13, 3-2, 5-2

Memory basics, A-1 - A-4

Memory mapping, B-2

Memory parity mode, 2-2

Memory space, 2-14, A-2

MSB, B-3

**N**

Notice, i

## O

Owner registration, 1-2

## P

Paging, B-2

Parameters

EMS device driver, 4-2

Print spooler, 4-9

Ram disk, 4-6

Parity checking, 2-8, 2-10

Physical layout, 2-1

Populating, 3-1

Port address, 2-2, 2-8, 2-11, A-2

Print spooler, 4-1

Base memory, 4-10

Baud rate, 4-10

Data bits, 4-10

ESPOOLEXE, 4-1, 4-8

Examples, 4-11

Expanded memory, 4-10

Extended memory, 4-10

Installation, 4-9

Memory types, 4-10

Parallel port, 4-10

Parameters, 4-9

Parity bit, 4-10

Path, 4-9

Print buffer, 4-9

Serial port, 4-10

Size, 4-10

Status of, 4-11

Stopbit, 4-10

XON/XOFF handshaking protocol,  
4-10

## Q

Quick checkout, 5-1

## R

RAM disk, 4-5 - 4-6, 4-8, A-1

Advantages, 4-5

Base memory, 4-7

Buffer size, 4-7

Capacity, 4-7

CONFIG.SYS file, 4-6

Default buffer, 4-7

Device driver, 4-5

Disadvantages, 4-5

EDISK.SYS, 4-1, 4-5 - 4-6

Examples, 4-6, 4-8

Expanded memory, 4-8

Extended memory, 4-7

Installation, 4-6

Parameters, 4-6

Path, 4-7

Removal, 4-6

Root directory entries, 4-7

Sector size, 4-7

Volume label, 4-8

RAM disk device driver

See RAM disk

READ.ME file, 1-5

Return Merchandise Authorization  
(RMA), 5-4

Returning merchandise, 5-4

## S

Section summaries, 1-3

Segment addresses, 4-3 - 4-4

Setting the AT Motherboard, 2-19

SETUP program, 3-8, 5-2

Software installation, 4-1 - 4-12

Starting address, 2-3, 2-16 - 2-17, 5-2

System requirements, 1-2

## T

Technical support

See Everex technical support

Testing, 3-7

Troubleshooting, 5-1 - 5-5

## U

Utility diskette, 1-2, 4-1 - 4-2, 4-6,  
4-9, 5-1

EDISK.SYS, 4-5

EMM.SYS, 4-2

ESPOOLE.EXE, 4-9

INST159.EXE, 2-4, 3-7

## W

Warranty card, 1-2

Window, B-2

## X

XON/XOFF handshaking protocol,  
4-10



---

**EVEREX SYSTEMS, INC.**  
**48431 MILMONT DRIVE**  
**FREMONT, CA 94538**

SALES: (510) 683-2100  
TECH SUPPORT: (510) 498-1115  
FAX: (510) 651-0728  
TELEX: 5101000590

*Effective September 2, 1991, the area code for  
Everex Systems, Inc. has changed to  
**510.***

*Please update all telephone numbers  
listed in this manual to reflect this change.*